



Style Definition: Style3: No bullets or numbering

---

# CITY OF TUCSON PUBLIC UTILITY ADMINISTRATIVE MANUAL

MAY 2021

---



DEPARTMENT OF  
TRANSPORTATION  
AND MOBILITY

# CITY OF TUCSON PUBLIC UTILITY ADMINISTRATIVE MANUAL

## Table of Contents

1. Authority .....	Pg. 3
2. References .....	Pg. 3
<b>3. Definitions .....</b>	
<del>3.4.</del> Purpose .....	Pg. 4
<del>4.5.</del> Work Restrictions and ROW Management .....	Pg. 7
<del>5.6.</del> Design Coordination .....	Pg. 8
<del>6.7.</del> Utility Locations .....	Pg. 10
<del>7.8.</del> Utility Corridor Approved Locations .....	Pg. 13
<del>8.9.</del> Submittal Requirements .....	Pg. 15
<del>9.10.</del> Construction and Material Replacement .....	Pg. 24
<del>10.11.</del> SWF Guidelines and Standards .....	Pg. 28

Formatted: Font: 14 pt



## CITY OF TUCSON PUBLIC UTILITY ADMINISTRATIVE MANUAL

<u>11.12.</u>	Design Review Steps .....	Pg.
40		
<u>12.13.</u>	Construction Procedures .....	Pg.
41		
<u>13.14.</u>	Inspection Expectations .....	Pg.
43		

### List of Figures

- Figure 1: Small Wireless Pole (SWF)
- Figure 2: Arterial Street Utility Location (per City of Tucson Technical Standards)
- Figure 3: Residential Street Utility Location (per City of Tucson Technical Standards)
- Figure 4: Conceptual Tree Placement Locations
- Figure 5: Aerial Heights
- Figure 6: Overlapping
- Figure 7: Barricades
- Figure 8: Erosion Exposure
- Figure 9: Local Floodplain
- Figure 10: Modern Streetcar
- Figure 11: Sight Visibility Triangle (SVT)
- Figure 12: Screening
- Figure 13: Low Profile Utility Marker
- Figure 14: Solid Waste Equipment Clearance
- Figure 15: Type 1 Utility Pole
- Figure 16: Type 2 Pole
- Figure 17: Type 3 Pole
- Figure 18: Type 3A Pole
- Figure 19: Type 3B Pole
- Figure 20: Accessory Screening
- Figure 21: SWF Poles in Amenity Zone
- Figure 22: Separation for Driveways and Trees
- Figure 23: Pole Location at Corner Property Line



# CITY OF TUCSON PUBLIC UTILITY ADMINISTRATIVE MANUAL

## List of Exhibits

- Exhibit A T-Top Modified PAG Standard Detail 216 Detail
- Exhibit B Pothole Patch
- Exhibit C Moratorium Patch Limits
- Exhibit D Holiday Restrictions
- Exhibit E Utility Waiver

## 1. AUTHORITY

The Constitution of the State of Arizona, The Tucson City Charter, Chapters 7a-D, Chapter 23, Chapter 25, and Chapter 30 of the Tucson City Code, and the Arizona Revised Statutes (ARS) Title 9, Chapters 4, 5, all other applicable federal, state and local laws, codes, rules and regulations, and the City's police powers and authority over the public Right-of-way or PUE.

## 2. REFERENCES

All construction shall be performed in accordance with the requirements of the following separate documents:

- Current Edition: PAG Standard Specifications for Public Improvements, and Standard Details for Public Improvements,
- Current Edition: Tucson Water Design Standards Manual, <https://www.tucsonaz.gov/water/dsm>
- Current Edition: Tucson Water, Standard Specifications and Details, <http://www.tucsonaz.gov/water/spec-book>
- Current Edition: Pima County Regional Wastewater Reclamation Department Standard Specifications and Details for Construction <http://www.pima.gov/wastewaterreclamation>
- Current Edition: Manual on Uniform Traffic Control Devices for Streets and Highways, and Amendments. [http://mutcd.fhwa.dot.gov/pdfs/2009/pdf\\_index.htm](http://mutcd.fhwa.dot.gov/pdfs/2009/pdf_index.htm)
- Current Edition: Arizona Supplement to the Manual on Uniform Traffic Control Devices (MUTCD), <http://www.azdot.gov/Highways/Traffic/Standards.asp>
- Current Edition: Additions by the City of Tucson to the Manual on Uniform Traffic Control Devices, for Temporary Traffic Control <http://dot.ci.tucson.az.us/traffic3/pdfs/City%20Additions%209-1-05.pdf>

**Commented [ES1]:** TEP Questions to City: Did COT use Pima County Roadway Design Manual as a reference to create this Manual? Similar standards and purview.

Does this Manual require approval by the COT Planning Commission?



## CITY OF TUCSON PUBLIC UTILITY ADMINISTRATIVE MANUAL

- Current Edition: Pima County and City of Tucson Department of Transportation Signing Manual, <http://www.dot.pima.gov/trafeng/DesignManual/SigningManual.pdf>
- Arizona Department of Environmental Quality (ADEQ), Waste Programs Divisions, Solid Waste Management, Petroleum-Contaminated Soils, Arizona Revised Statutes ARS § 49-851.A.3, and ARS § 49-152. <http://www.azdeq.gov/environ/waste/solid/special.html>
- Current Edition: Pima County and City of Tucson Department of Transportation Pavement Marking Design Manual, October 2002 .  
<http://dot.pima.gov/trafeng/DesignManual/PavementManual.pdf>

Additions By The City of Tucson To The Manual On Uniform Traffic Control Devices For Temporary Traffic Control <https://www.tucsonaz.gov/tdot/permits-and-codes-section>

- Grant of a Franchise ARS § 9-501
- National Electric Safety Code, <https://standards.ieee.org/products-services/nesc/index.html>
- City of Tucson Uniform Development Code Technical Standards Manual  
[https://codelibrary.amlegal.com/codes/tucson/latest/tucson\\_az\\_udc/0-0-0-10261#JD\\_TECHNICALSTANDARDSMANUAL](https://codelibrary.amlegal.com/codes/tucson/latest/tucson_az_udc/0-0-0-10261#JD_TECHNICALSTANDARDSMANUAL)

Formatted: Highlight

Formatted: Font color: Auto, Highlight

Formatted: Highlight

Formatted: Highlight

DRAFT



# CITY OF TUCSON PUBLIC UTILITY ADMINISTRATIVE MANUAL

## 3. DEFINITION

Commented [SC2]: Please alphabetize the definitions

For the purposes of this City of Tucson Public Utility Administrative Manual (the “Manual”):

“Accessory Equipment” means any ancillary equipment that is needed to complete the infrastructure that is above ground or requires excavation for foundations and is necessary for the operation and support of utility infrastructure and service.

Formatted: Font color: Auto, Highlight

Formatted: Font color: Auto

“Annual Permit” means: (i) a right of way permit that allows applicants to do temporary work not requiring excavation, inspection, and lasting no longer than two hours; or (ii) Emergency Restoration; or (iii) removal of Topped Poles. This permit does not allow impact to street capacity for arterials and collectors and daily activity must be reported to the Permit Center for information and permit assignment planning.

Formatted: Not Highlight

Formatted: Highlight

Formatted: Highlight

“Antenna” - communications equipment that transmits or receives electromagnetic radio frequency signals used to provide wireless service.

“Cantenna” – that part of a small cell facility typically located at the top of small cell poles, that covers, shrouds, or otherwise conceals that part of the facility used for the purpose of housing the antenna(s), antenna mount(s), cable connections, radio equipment and other hardware.

“Collocate or collocation” - to install, mount, maintain, modify, operate or replace wireless facilities on, within or adjacent to a wireless support structure or utility pole.

“CSA” means cost sharing agreement between the Utility Company and Tucson Department of Transportation (DTM) for expectations and assignment of costs related to utility removal from a City street made as part of a capital or pavement maintenance project.

Formatted: Highlight

“DTM” means Department of Transportation and Mobility.

“Emergency Restoration” - a situation requiring prompt action to restore system outage, public safety, or restoration of critical equipment to support utility operations.

Formatted: Highlight

FCC – The Federal Communications Commission.

Commented [SC3]: Might consider a separate section for a List of Abbreviations. I've seen this in other manuals I have reviewed.

“Maintenance” means work to existing infrastructure that requires equipment relocation, repair, replacement, or upgrades.

Formatted: Highlight

“Major Impact Traffic Zone” (“MITZ”) means major impact traffic zone and refers to arterials or collectors that provide transportation corridors throughout the City of Tucson. It also includes the downtown city center and its immediate surroundings. **It is generally bounded by Toole Ave/4<sup>th</sup> Avenue, 6<sup>th</sup> St, Granada Avenue, and Cushing Street.**

Formatted: Highlight

Formatted: Font: Bold, Highlight

Formatted: Font: Bold

Formatted: Indent: Left: 0"



## CITY OF TUCSON PUBLIC UTILITY ADMINISTRATIVE MANUAL

“MCP” means mobility control plan and was previously known as a traffic control plan. All barricades shown on plans must also consider all forms of mobility including pedestrians, bicyclists, and transit riders when planning a construction activity that may restrict a mobility function for the safety of the users of various mobility categories.

“Microsurface Treatment” means a slurry type pavement treatment having aggregate size qualifying it to be considered a microsurface as defined by PAG Specifications, Section 404.

Formatted: Highlight

“NESC” means the National Electric Safety Code.

Formatted: Highlight

NEC means the National Electric Code

“New Projects” means new placement of utility infrastructure and does not include services, maintenance, or emergency repairs.

Formatted: Highlight

Formatted: Highlight

“Night” means hours defined pPer Tucson City Code 16-31

Commented [DJ4]: TEP requests consistency when using the term night

Formatted: Highlight

“Owner” - A person with a legal or equitable interest in ownership of real or personal property.

“Power Sharing Agreement” means– the power sharing agreement between the City and a cellular company that is added to a Site License Agreement for an individual SWF. The agreement determines the rate and obligates the cellular company to pay the City an annual fee to use an existing power source for the power consumption of the SWF radio and related equipment to a City owned street light pole intended to be shared.

Formatted: Highlight

“Professional” means a person who is knowledgeable in a recognized area or specialty, trained, and performs the design of respective work as a livelihood.

“Public rights-of-way or ROW” - Public roads, access ways, sidewalks, or similar facilities.

“PUE” means public utility easement and describes the allowance of designated land for the use and installation of utilities in compliance with the City’s construction requirements.

“Right-of-way (“ROW”)” - The area on, below or above a public roadway, highway, street, sidewalk, alley, or utility easement. Right-of-way does not include a Federal Interstate Highway, a state highway

Formatted: Left, Indent: Left: 0", Don't adjust space between Latin and Asian text, Don't adjust space between Asian text and numbers

Formatted: Font: Not Bold

Formatted: Font: Not Bold



## CITY OF TUCSON PUBLIC UTILITY ADMINISTRATIVE MANUAL

or state route under the jurisdiction of the Department of Transportation, a private easement, or property that is owned by a special taxing district.

"Small wireless facility" - a wireless facility that meets both of the following qualifications:

- All antennas are located inside an enclosure of not more than six cubic feet in volume or, in the case of an antenna that has exposed elements, the antenna and all of the antenna's exposed elements could fit within an imaginary enclosure of not more than six cubic feet in volume.
- All other wireless equipment associated with the facility is cumulatively not more than twenty-eight cubic feet in volume, or fifty cubic feet in volume if the equipment was ground mounted before August 9, 2017. The following types of associated ancillary equipment are not included in the calculation of equipment volume pursuant to this subdivision:
  - An electric meter.
  - Concealment elements.
  - A telecommunications demarcation box.
  - Grounding equipment.
  - A power transfer switch.
  - A cutoff switch.
  - Vertical cable runs for the connection of power and other services.

"Standard Utility Placement" - a general approved corridor for the placement and location of respective utilities within the ROW as shown in Figures 2&3

"Stealth Design Techniques" - The use of materials, colors, screening, undergrounding, or other concealment elements intended to blend the new equipment and existing pole into the surrounding setting.

"TNE" means temporary noise exemption and is required for work performed ~~done~~ during night hours at night.

"Topped Pole" - occurs when the electrical facilities are removed from the top of a pole, the pole is cut, and telecommunications equipment remains on the pole.

"UCC" means Utility (Planning) and Coordination Committee and established by ordinance 4465 for the planning and coordination of the construction and modification of existing and proposed infrastructure within the public right-of-way.

"Utility Company" - -A public or private entity seeking to construct, manage, operate or maintain infrastructure and/or facilities within, on, across, above or beneath the public right-of-way for public or private use and includes, but is not limited to, public service corporations, telecommunications corporations, wireless service providers, wireless infrastructure providers, video service providers, common carriers, sewer corporations, fiber companies and gas and water utilities.

"Utility pole" - a pole or similar structure that is used in whole or in part for communications services, electric distribution, lighting or traffic signals. Utility pole does not include a monopole.

Formatted: Indent: Left: 1", No bullets or numbering

Formatted: Highlight

Formatted: Highlight

Formatted: Highlight

Formatted: Highlight

Formatted: Highlight

Formatted: Font: Not Bold

Formatted: Indent: Left: -0.1"





## CITY OF TUCSON PUBLIC UTILITY ADMINISTRATIVE MANUAL

"Utility Waiver Request"- the form in Exhibit E that a Utility Company must submit to receive a waiver of applicable Manual requirements.

"Verticality" means a vertical element located in the public right of way and may include utility poles, streetlight poles, and sign posts.

"Voter approved Franchise Agreement"- a voter approved franchise granted by the City to a Utility Company pursuant to A.R.S. § 9-502."

Formatted: Highlight

Formatted: Highlight

Commented [DJ5]: Waiver provision would be useful for all requirements in the Manual

Formatted: Highlight

Formatted: Highlight

Formatted: Highlight

Formatted: Highlight

Formatted: Highlight

Formatted: Highlight

Commented [SC6]: Might consider a separate section for a List of Abbreviations. I've seen this in other manuals I have reviewed.

### 4. PURPOSE

The purpose for this manual is to

- Inform Utility Companies of the requirements and expectations for processing a request to construct and install utility infrastructure within the City of Tucson right of way (ROW) or PUE.
- Advise Utility Companies of shared space and approved utility locations to coexist within a limited space.
- Advise Utility Companies of what must be considered when designing, coordinating, and constructing public utility main infrastructure within City of Tucson ROW and maintaining existing mobility, landscaping, access, safety, and street materials as deemed to be in the public's interest.



## CITY OF TUCSON PUBLIC UTILITY ADMINISTRATIVE MANUAL

- Inform the Utility Companies of the permit communication expectations for the City and its residents.
- Provide City Staff with direction for review, approval, and inspection of work within the ROW.

The Utility Companies shall acknowledge and understand the steps the City of Tucson will need to follow for the City to assess the complexity of the project presented as it pertains to the public, the ROW limitations, and needs and uses. Mobility concerns, communication, and construction quality expectations will be addressed by the conditions of this manual as discussed herein.

### **WHERE AND WHEN DOES THIS APPLY?**

This document applies to any utility infrastructure in the public ROW.

New fiber companies to the City of Tucson shall make application and receive approval for a license agreement, provide proof of operating area approval, and must be current in annual fee payments.

Utility Companies having voter approved Franchise Agreements must follow the agreement and the manual.

The number of open permits per Applicant may affect the approval of new ROW applications.

The Applicant shall make all efforts to ensure see that permits are completed and closed out before the expiration date, within 30 days from the permit date of expiration

**Commented [DJ7]:** How would amendments and updates occur to the manual? What would be the process and stakeholder participation?

**Formatted:** Highlight

**Formatted:** Highlight

**Formatted:** Highlight

**Formatted:** Highlight

### **4.1 SPECIAL LOCATIONS AND CONSIDERATIONS**

The requirements of work allowed will vary based upon the type of utility and its location in relation to other utilities in the same right-of-way. Varying requirements may be imposed upon the Utility Company such as work hours, seasonal restrictions, events, other work scheduled, and possible differing restoration methods and materials to address the concerns of businesses, City events, capital projects, commuters, pedestrians, bicyclists, transit users, and other stakeholder needs. Approval of permits and work dates or work hours may be delayed to account for and accommodate the users of the ROW for transportation, other requests, and activities.

Deviation from a standard utility placement location that complies with all aspects of this utility manual may be approved in advance through a waiver request that includes: the reason for the request and evidence that all possible locations meeting the intent of the initial approved location placement have been explored and found infeasible. Guidelines for alternate locations included herein may be used to demonstrate this intent should a waiver be necessary. Waivers will be granted or denied at City's sole discretion.

**Commented [ES8]:** What is a standard location? Is this the location that's approved by permit?

Recommended that this become a defined term



## CITY OF TUCSON PUBLIC UTILITY ADMINISTRATIVE MANUAL

Design and construction within **Major Impact Traffic Zones (MITZ)** shall have special design considerations, utility location changes, work hour restrictions, and other specialized considerations applied to the review and approval that may not be standard to a normal approval.

Design and construction in residential areas will also have special design considerations, utility location changes, work hour restrictions, and other specialized considerations applied to address the needs and the concerns of the resident. This may include landscape and tree planting opportunities, off-street parking, mail and package delivery, pedestrian access, and placement of above ground equipment.

Work done at Night will require a **temporary noise exemption (TNE)** and special inspection fees, except Emergency Restoration. Work **to be done on the weekends or after hours should be requested in advance and** may have special inspection fee rates associated with the overtime request.

Formatted: Highlight

Formatted: Highlight

Formatted: Highlight

### 4.1.1 Row Permit Required

Any activity in the ROW requires a ROW permit. This advises the City of Tucson of the activity and if there is a need to follow up with an inspection for safety or quality; and to let the residents or business know of activity and who to contact to address their specific concerns.

If maintenance is required, an **Annual Permit** exists for the expediency of this work. Utility Companies should determine if it is right for them. If work on an arterial or collector street is necessary, a **Mobility Control Plan** (A.K.A Barricade Plan) will need to be submitted for review and approval before work begins.

Formatted: Highlight

Work that begins (other than for Emergency Restoration) without a ROW permit being issued or has expired is subject to a \$2,500 citation per City Code Chapter 25- 45.1., in addition to any additional remedies available to the City by law, including a Stop-Work Order.

Formatted: Highlight

### 4.1.2 Public Notification Program

Businesses, residents, and affected stakeholders shall be allowed to view and comment on all **new projects** proposed **s in the planning/design stage**. The Utility Company **shouda#** reach out to the affected areas and address concerns before designs have completed their review for approval. Proof of public outreach will need to be provided as part of the review submittal in the design stage.



# CITY OF TUCSON PUBLIC UTILITY ADMINISTRATIVE MANUAL

## 4.1.3 Road Appearance

It is the desire of the City of Tucson to keep all roads looking uniform in appearance. The Utility Company shall add additional surfacing material over disturbed pavement areas to keep the road looking uniform in appearance to its surroundings as described herein. Discussion of the limits and expectation details is contained herein.

Formatted: Highlight

Opportunities to partner with the Department of Transportation and Mobility (DTM) for roads scheduled to be resurfaced may be available to help coordinate the timing and reduce the costs for pavement restoration. It is in the best interest of the Utility and the City to minimize impacts, disruption, and costs associated with any activity where possible with advanced planning and continued communications.

## 4.1.4 Support Drawings

All Projects to be installed shall require drawings that accurately depict the utilities and street infrastructure. Project documents Design shall be prepared by design professionals, knowledgeable of their respective industry standards and requirements, as allowed by the Arizona State Board of Technical Registration, or as required by respective Utility Company owning the infrastructure.

Formatted: Highlight

Formatted: Highlight

Formatted: Highlight

Formatted: Highlight

A copy of the Record drawings shall be provided to the inspector at the close out of the permit where applicable. It shall depict required upon completion showing the complete as-built infrastructure, including all horizontal runs of power, communications, or other facilities necessary to the installed infrastructure as well as any changes made during the construction. A certification line must be included as part of the formatting attesting to the accuracy and quality of the work.

Formatted: Highlight

The Utility Company shall be responsible for any below ground damage caused by their work and bears the responsibility to pay for and make any repairs or replacement to infrastructure or services found damaged by this work.

## 4.1.5 Abandoned Facilities

Remnants of infrastructure that is replaced or relocated, including any structure at or above grade (ground level), shall not be left in place unless first approved by the City and only under special circumstances. The cost to the Utility Company shall not be a reason for not removing the abandoned infrastructure.



## CITY OF TUCSON PUBLIC UTILITY ADMINISTRATIVE MANUAL

Work may be deferred to a later date and coordinated with DTM capital or maintenance projects or combined with other construction activity that exposes the material to reduce the costs associated with the removals. The cost to remove the abandoned material shall be borne by the owner of the infrastructure and if made in conjunction and cooperation with a DTM capital project, the payment amount, and details for collecting or assisting with its removal shall be captured by a Cost Sharing Agreement (CSA).

Formatted: Highlight

DRAFT



# CITY OF TUCSON PUBLIC UTILITY ADMINISTRATIVE MANUAL

## 5. WORK RESTRICTIONS AND RIGHT-OF-WAY MANAGEMENT

Work is evaluated based upon other ROW activity and events. Restrictions and scheduling of work will be made a condition of the permit. Here are some things to consider:

**Holiday Moratorium-** During the period of Thanksgiving Day to January 2<sup>nd</sup> issuance of new permits is reduced to work affecting certain arterials and collectors due to the increased number of winter visitors during the referenced time of year. [See link below for more information.](#) These restrictions do not apply to Emergency Restoration. Construction sites in progress along these routes shall cooperate by minimizing impact to street capacity and business access during this time. A list of streets affected can be found in Exhibit D-<https://www.tucsonaz.gov/tdot/barricading-and-detours>. New work may be approved with special conditions to be done at Night provided it meets the intent of this restriction and the requirements described herein.

**Street Capacity Restored-** lanes that are restricted shall be strongly encouraged to be restored for use by the community for the use and safety of including drivers, pedestrians, and bicyclists at the end of shift each day.

**Events-** the Utility Company will consider and account for work restrictions during temporary events. Most events occur downtown. Traffic congestion shall be minimized by complying with scheduling and ROW work hourly coordination.

**Other Construction-** capital projects, emergency repairs, and other types of work may impact the schedule work proposed by the Utility Company's permit request. The Utility Company shall be informed by the City of these occurrences and cooperate with emergency or planned work requests.

**Development-** Utility Companies shall be aware and consider other business operations and access, capital project schedules, noise restrictions, peak traffic hour times, and holiday or events. Communication with all affected including commuters through message boards and public service announcement updates is desired.

**Night Work-** construction Downtown, in congested areas, residential areas, and MITZ may not be allowed during normal business hours in some areas. A **Temporary Noise Exemption (TNE)** pursuant to Tucson Code section 16-31(d), may be necessary if the construction zone impacts the normal use of the street and business access when working at night. The link to request and submit one can be found at <https://tucsonaz.seamlessdocs.com/f/NoiseExemption>.

**Street or Intersection Closing-** Closing of streets or intersections will not be allowed in residential areas without written permission, neighborhood awareness, and a TNE unless it is for Emergency Restoration.

Closing of arterial or collector intersections may be considered on a case-by-case basis if work is done at night to minimize impacts to businesses, commuters, and emergency services. For

- Formatted: Highlight
- Formatted: Font: Not Bold, Highlight
- Commented [DJ9]: What does this mean?
- Formatted: Highlight
- Formatted: Highlight
- Formatted: Highlight
- Formatted: Highlight
- Formatted: Highlight
- Formatted: Highlight
- Formatted: Highlight
- Formatted: Highlight

Formatted: Highlight

Formatted: Highlight

Formatted: Highlight

Formatted: Highlight



## CITY OF TUCSON PUBLIC UTILITY ADMINISTRATIVE MANUAL

New Projects, advanced message board notifications are required in addition to a TNE as discussed above.

Formatted: Highlight

**Weather-** Utility Companies should account for seasonal weather delays when considering and scheduling. Permittees should consider work on weekends and longer shifts to meet the ROW Permit expiration date. Applicable [inspection](#) overtime fees may apply.

## 6. DESIGN COORDINATION

### PLANNING AND PROGRAMMING COORDINATION

It is important that the City of Tucson is made aware of upcoming utility projects that may impact planned capital projects and other event activities within the City limits. A monthly Utility Coordination Meeting will be held virtually or physically where all utility companies may be able to present proposed projects so that potential issues may be coordinated and resolved before proceeding. The City's Utility Coordinator will chair the **Utility Coordination Committee (UCC)**. All utility companies shall have an opportunity to attend and present proposed projects.

Daily and scheduled maintenance activity shall be reported to the Utility Coordination Section through the following link: [tdotpermitcenter@tucsonaz.gov](mailto:tdotpermitcenter@tucsonaz.gov) for the City of Tucson. **Annual Permit** reporting shall have a heading stating it is "Annual Permit Work Activity." Impacts to commuter traffic is important [forte DTM](#) to know and report on. This includes flushing of fire hydrants, power outages, pole removals, and other related routine maintenance activities that may affect street capacity with trucks, equipment, water, materials, or debris.

Formatted: Highlight

### 6.1 PUBLIC INVOLVEMENT

Mobility, property and business access, safety, pavement damage, interruption of services, and the public awareness are areas of concern expressed by the City's inhabitants. The City of Tucson has adopted public involvement requirements for all City capital projects and similar information and opportunities for public comment will be afforded to residents, business owners, and users of the public ROW for utility infrastructure construction in the public ROW.

#### 6.1.1 Public Notification Process (Design)

All NEW or major utility installations, major repair, or capital infrastructure replacement shall follow this process. **This requirement does not apply to regular maintenance, emergency restoration or individual business and new house service connections.** This requirement shall occur during the **design stage**- concurrently with plans that are submitted for permit review and approval. Notifications during construction follow a different protocol [and are required for all utility permits](#). Here are the steps to follow:

Formatted: Highlight

1. Prepare an Informational Letter describing the work planned and the benefits provided by this improvement. Describe when the design is expected to be completed and the expected construction start date and duration, and where residents may send their responses to the

Formatted: Highlight



## CITY OF TUCSON PUBLIC UTILITY ADMINISTRATIVE MANUAL

Utility Company and [DOT-Engineering-Review-Section@tucsonaz.gov](mailto:DOT-Engineering-Review-Section@tucsonaz.gov). Notifications shall be sent out to residents and businesses within a **minimum 300-foot radius** of the proposed project limits, the City's Utility Coordinator, the affected Ward office, and one to the Neighborhood representative (if one exists). **The City shall provide the addresses of the impacted residents and neighborhood association contact information to the Utility Company requiring notification. The Utility Company shall not be held responsible for failing to notify those not included on this list.**

2. **Contact —Meet with the** DTM staff to discuss where the infrastructure will go in relation to current utility locations. For arterial and collector streets, discuss how business access, pedestrians, and bus service will be maintained. For residential locations, if applicable, describe how access and typical operations like mail/ package delivery will be made; how garbage pickup will be managed; and how on street parking will be accommodated during construction.



3. For above ground equipment, identify the potential site for placement of the above ground equipment within the project area or neighborhood. Factors to consider in selecting the site should include aesthetics, technical/engineering restrictions and **PUE** and/or **ROW** areas. Identify several alternate locations- if possible. Above ground equipment does not include manhole rims, water box valves, pullboxes, or other accessories that are flush with the pavement or ground.

4. For **new** above-ground infrastructure in residential areas, the packet will include a "before" and "after" (with the new structure superimposed and all accessory equipment) picture plus a diagram showing all work considered to be performed, including trenching or boring in the area. A 15-business day citizen response period will begin upon DTM advising the Applicant the Application is complete. A list of residents to whom a packet was sent must be provided to DTM during the plan review. Residents who have been notified of the improvements may send their responses to

4. [DOT-Engineering-Review-Section@tucsonaz.gov](mailto:DOT-Engineering-Review-Section@tucsonaz.gov)

Formatted: Font: 12 pt

Formatted: Font: 12 pt, Highlight

Formatted: Highlight

Formatted: Font: 12 pt, Highlight

Formatted: Font: 12 pt

Formatted: Font: 12 pt, Highlight

Formatted: Highlight

Formatted: Font: 12 pt, Highlight

Commented [SC10]: Can we format all photos with a navy blue border?

Formatted: Highlight

Formatted: Highlight

Formatted: List Paragraph, Indent: Left: 0.25", Outline numbered + Level: 1 + Numbering Style: 1, 2, 3, ... + Start at: 1 + Alignment: Left + Aligned at: 0" + Indent at: 0.25"

Field Code Changed



## CITY OF TUCSON PUBLIC UTILITY ADMINISTRATIVE MANUAL

5. If the infrastructure is to be in a public utility easement (PUE) or less than 50-ft from a residence, a utility company customer service representative will attempt to make personal contact with the property owner either by letter, phone, virtual meeting, or in person to discuss any concerns the property owner might have. Document conversation to include time, date, person spoken with, and result of conversation. Share response with the DTM Utility Coordination team during the review period.

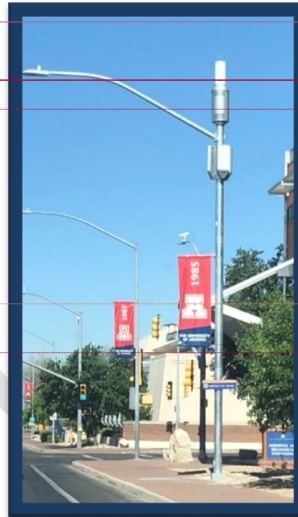

Commented [SC11]: Appears this is not the first figure. I might suggest eliminating the titles "figure X-XXX" altogether unless explicitly referenced in the body of text.

Formatted: Font: 12 pt

Formatted: Font: 12 pt, Highlight

Formatted: Highlight

Formatted: Not Highlight

Formatted: Font: 12 pt

Formatted: Font: 12 pt

Formatted: Font: 12 pt

Formatted: Normal

Formatted: Indent: Left: -0.05"

Formatted: Highlight

6. ~~When a project is identified and~~ the logistics have been identified and discussed with the City's Utility Coordination team, the Utility Company shall post a 2'x1.5' wire frame sign at all locations where above ground equipment or accessory equipment will be located. The sign shall contain information as to where details can be found, the contact person for the utility company, and where comments can be emailed to. If the concerns expressed cannot be resolved through the design, a UTILITY WAIVER may be submitted for review and approval justifying the site location based upon the criteria described in this manual.

7. The City places a great emphasis on transparency and public engagement and strongly encourages Utility Companies to show a willingness to work with residents and select alternate locations if there is a strong resistance to an initial placement.

Any use of a PUE shall be consistent with the terms of the easement and applicable law, code and regulation.

**If the Utility Company already has a proactive and comprehensive public information program, they implement in advance of New Projects that meet the intent of this requirement, they may continue to follow it in lieu of these steps subject to approval from the City's Utility Coordinator.**

Formatted: Highlight

## 7. UTILITY LOCATIONS

The location of the work is a key element in the assessment of impacts to the community. The duration of the permit, the time when work can be done, and construction details that must be followed are described herein. The **Utility Company** must make sure that the location of all infrastructure installed is carefully documented for future reference. Considerations to move a utility location to another location may be approved provided the location is compatible with other utilities, their service lines, and approved by the City. The following items will be reviewed for compatibility, use, and any special requirements associated with the utility installation:



## CITY OF TUCSON PUBLIC UTILITY ADMINISTRATIVE MANUAL

- Utility corridor **approved utility locations**
- Utility separation requirements
- Depths and Heights
- Proximity to Modern Streetcar
- Downtown
- Other

Formatted: Highlight

Formatted: Font: 12 pt

Formatted: Normal, No bullets or numbering

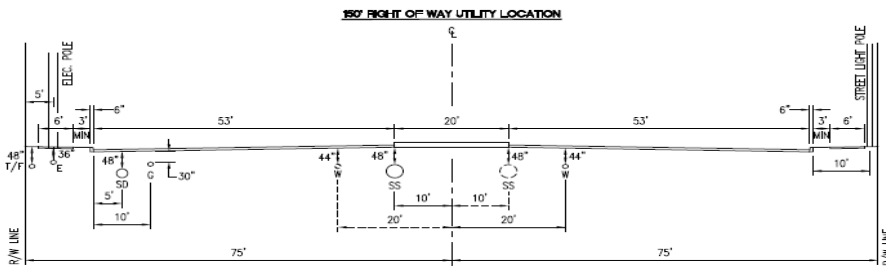

### NOTES:

- 1) TELECOM/FIBER LINE (T/F) CAN BE INSTALLED BEHIND SIDEWALK, OVERHEAD, OR JOINT TRENCH WITH STREET LIGHT BEHIND CURB.
- 2) STORM DRAIN (SD): 5' FROM CURB UNDER PAVEMENT.
- 3) ELECTRIC POLE: 5' FROM R/W LINE, ELECTRIC LINE (E) CAN BE JOINT TRENCH BEHIND CURB.
- 4) STREET LIGHT POLE: BETWEEN CURB AND SIDEWALK OR BEHIND SIDEWALK (10' FROM CURB).
- 5) GAS (G): 10' FROM CURB UNDER PAVEMENT.
- 6) SANITARY SEWER (SS): 10' ON EITHER SIDE OF CENTERLINE (UNDER MEDIAN OR PAVEMENT).
- 7) WATER (W): 20' ON EITHER SIDE OF CENTERLINE UNDER PAVEMENT. FIRE HYDRANT TO BE BETWEEN CURB AND SIDEWALK.
- 8) SIGNS: BETWEEN CURB AND SIDEWALK.

### SEPARATION:

- 1) A 6' MIN HORIZONTAL SEPARATION FROM ANY DRY UNDERGROUND UTILITY SHALL BE PROVIDED FOR WATER MAINS, SEWER MAINS, AND OTHER UTILITIES. THE MIN HORIZONTAL SEPARATION IS MEASURED FROM OUTSIDE WATER/SEWER MAIN TO THE OUTSIDE OF THE UNDERGROUND UTILITY.
- 2) A 10' HORIZONTAL SEPARATION BETWEEN WET UTILITIES SHALL BE PROVIDED.
- 3) A MIN 4' VERTICAL SEPARATION BETWEEN WET UTILITIES SHALL BE PROVIDED.
- 4) A 5' MIN HORIZONTAL SEPARATION FROM ANY DRY UNDERGROUND UTILITY SHALL BE PROVIDED FOR WATER SERVICES AND SEWER SERVICES. THE MIN HORIZONTAL SEPARATION IS MEASURED FROM OUTSIDE OF WATER/SEWER SERVICES TO THE OUTSIDE OF THE UNDERGROUND UTILITY.
- 5) A 1' MIN VERTICAL SEPARATION FROM ANY DRY UNDERGROUND UTILITY CROSSING SHALL BE PROVIDED FOR WATER MAINS, WATER SERVICES, SEWER MAINS, AND SEWER SERVICES. THE MIN VERTICAL SEPARATION IS MEASURED FROM OUTSIDE OF WATER/SEWER MAIN/SERVICE TO OUTSIDE OF THE UNDERGROUND UTILITY.
- 6) A 4' MIN VERTICAL CLEARANCE UNDERNEATH EXISTING TREES OR VEGETATION FOR WET AND DRY UTILITIES.
- 7) A 5' MIN VERTICAL AND HORIZONTAL CLEARANCE NEAR OR UNDERNEATH MODERN STREETCAR TRACKS FOR ALL UTILITIES.
- 8) ANY AND ALL, MORE STRINGENT SEPARATION REQUIREMENTS REQUIRED BY FEDERAL, STATE, OR LOCAL CODES OR ORDINANCES SHALL TAKE PRECEDENCE.

Figure 2 - Arterial Street Utility Location

Commented [DJ12]: TEP proposes the following changes to the diagram:

- Notes add the word recommended separation to the diagram
- Change feet referenced in note 3, from 5' to 8
- Separation note 1, 2, and 4, change 6' to one foot and anything that falls within the cone of influence requires review with Pima County Wastewater



## CITY OF TUCSON PUBLIC UTILITY ADMINISTRATIVE MANUAL

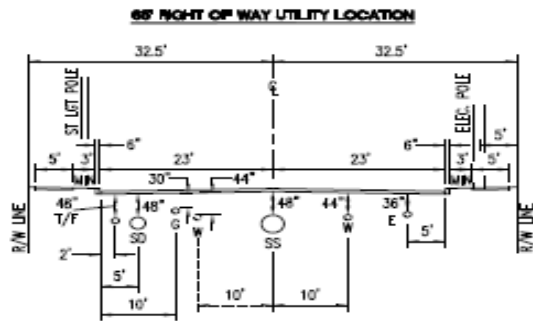

**NOTES:**

- 1) TELECOM/FIBER LINE (T/F) CAN BE INSTALLED 2' FROM CURB UNDER PAVEMENT
- 2) STORM DRAIN (SD): 5' FROM CURB UNDER PAVEMENT.
- 3) ELECTRIC POLE: 5' FROM R/W LINE, ELECTRIC LINE (E) 5' FROM CURB UNDER PAVEMENT OR JOINT TRENCH BEHIND CURB
- 4) STREET LIGHT POLE: BETWEEN CURB AND SIDEWALK OR BEHIND SIDEWALK (10' FROM CURB).
- 5) GAS (G): 10' FROM CURB UNDER PAVEMENT.
- 6) SANITARY SEWER (SS): CENTER OF ROAD.
- 7) WATER (W): 20' ON EITHER SIDE OF CENTERLINE UNDER PAVEMENT. FIRE HYDRANT TO BE BETWEEN CURB AND SIDEWALK.
- 8) SIGNS: BETWEEN CURB AND SIDEWALK.
- 9) IF LOCATION IS NOT POSSIBLE DUE TO SEPARATION REQUIREMENT RESTRICTIONS, A WAIVER TO INSTALL IN THE PARKWAY (BETWEEN THE CURB AND PROPERTY LINE) MAY BE CONSIDERED. THE LINE MUST BE NO LESS THAN 4" DOWN IF INSTALLED IN THE PARKWAY. A DECISION TO THE WAIVER REQUEST WILL BE MADE ON A CASE BY CASE BASIS.

Commented [DJ13]: TEP proposes the same changes in the above comments

Figure 3 – Residential Street Utility Location

### 7.1 TREE LOCATION AND PLANNING

The City of Tucson is committed to planting 1,000,000 trees in the right-of-way for shade to pedestrian paths between the curb and the property line. All Utility Companies shall keep this in mind when planning, designing, or modifying their infrastructure within City of Tucson rights-of-way.

Formatted: Highlight

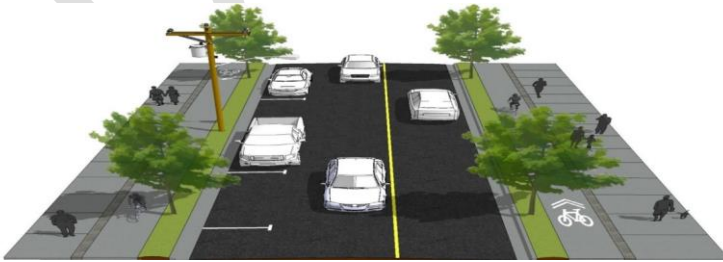

Figure 4 – Conceptual Tree Placement Location

## CITY OF TUCSON PUBLIC UTILITY ADMINISTRATIVE MANUAL

### 8. UTILITY CORRIDOR APPROVED LOCATIONS

#### WET Utilities

All wet utilities shall generally be located under the street pavement for ALL streets and street classifications unless they exist in a pre-existing utility easement. Wet utilities are liquid or gas, conveyed in conduits or pipes that could be under pressure.

WET utilities may be located outside of the pavement area provided they do not conflict with proposed tree or water harvest basin locations; do not cause sight visibility issues for drivers using intersections or driveways; and are compatible with the utilities already in the vicinity located.

WET utilities may be in dedicated utility easements or in prior rights easement locations.



#### DRY Utilities

Dry utilities include power, cable, or fiberoptic communication lines and their supporting equipment. These may be located on existing power poles or below ground. SWF equipment shall be screened in accordance with this manual.

If dry utility infrastructure is above ground, the poles, pedestals, equipment cabinets, or other supporting equipment should not interfere with the sight visibility of drivers at intersections, alleys, or driveways. Also, placement of new equipment shall not be positioned to interfere with pedestrian paths or landscape amenities- future or present.

Support poles are approved to be positioned near the right of way /property line. All dry utility lines must be coordinated in height so to not be a danger to those who must do maintenance to the equipment under or attached to poles and their lines. For communication/fiberoptic or cable lines that are currently aerial, a 10-ft vertical separation (or as allowed/required by the Utility Company) is typically required between overhead power and communication or street lighting lines or equipment

If dry utilities are located below ground, the conduits constructed under the pavement shall maintain the designated separation requirements described herein. If this is not possible, a joint trench with compatible utilities can be made.

Communication, fiber, cable, or electric conduits installed underneath pavement between the curb and the property line shall be constructed with special protection such as a concrete cap when the depth is less than two feet or less.

Formatted: Highlight

Commented [DJ14]: Due to the number of utilities in the curb and property line, TEP recommends this change (noise mitigation and closure of roads will become an increased problem if all conduit is incased in concrete)

TEP only does special protections when conduit did not have NESC minimum coverage or all things 46kV above

Formatted: Highlight

Formatted: Highlight



## CITY OF TUCSON PUBLIC UTILITY ADMINISTRATIVE MANUAL

Approval may be given to install utilities in alignments generally reserved for another utility type; but, should other than an approved location shall be requested, require confirmation by the reviewer and formal approval by the City Engineer through as part of a UTILITY WAIVER request.

Formatted: Highlight

Formatted: Highlight

Formatted: Highlight

Aerial installation shall be located on approved pole locations with permission by the utility pole owner. No new aerial attachments shall be made on Topped Poles -scheduled to be removed.-

### 8.1 UTILITY SEPARATION AND CLEARANCES

- A 5-ft minimum horizontal separation from any dry underground utility shall be provided for water mains, sanitary sewer mains, and other utilities. The minimum horizontal separation is measured from outside of water/sewer main to the outside of the underground utility.
- A 6-ft horizontal separation between wet utilities shall be provided where possible.
- A minimum 2-ft vertical separation between wet utilities shall be provided unless additional pipe material modifications are made to the system at the crossing per agency requirements.
- A 5-ft minimum horizontal separation from any dry underground utility shall be provided for water services and sewer services. The minimum horizontal separation is measured from outside of water/sewer services to the outside of the underground utility.
- A 2-ft minimum vertical separation from any dry underground utility crossing for water mains, water services, sewer mains, and sewer services. The minimum vertical separation is measured from the top of water/sewer main/service to outside of the underground utility.
- A 4-ft minimum vertical clearance underneath existing trees or vegetation shall be maintained for wet and dry utilities. Trees shall not be planted over existing sanitary sewer or water mains.
- A 5-ft minimum vertical and horizontal clearance near or underneath Modern Streetcar tracks for all utilities.
- **Any and all, more stringent separation requirements required by the owner of the infrastructure, Federal, State, Local Codes, ordinances shall take precedence, or applicable governing national standards.**

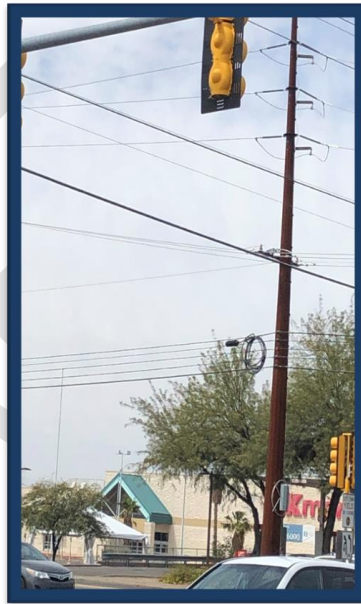

Figure 5- Aerial Heights

Formatted: Bulleted + Level: 1 + Aligned at: 0.25" + Indent at: 0.5"

Formatted: Highlight

Formatted: Font: 12 pt, Bold

A Utility Company requesting a variance from the above minimum clearances must do so in writing in the form of a Utility Waiver Request to the Engineering Division, Utility Coordination Section as part of the permit application. The request shall identify each utility clearance



## CITY OF TUCSON PUBLIC UTILITY ADMINISTRATIVE MANUAL

requirement for which a variance is requested and the reasons why a variance should be granted. The Utility Coordinator will decide whether a variance should be granted. When utility conflicts are found during construction, all changes and variances must be preceded by an approved plan revision.

### 8.2 AERIAL INSTALLATION HEIGHTS

Aerial electric, cable, or fiber optic lines shall be a minimum of 18-ft high when crossing signalized street intersections, pavement, or alleys. The height above ground, outside of paved areas and all other intersections shall be no less than 16-ft at lowest sag locations. Adding of additional poles shall not be considered if the height cannot be maintained at the sag between pole spacing. The lines in violation shall be raised or moved to an underground location per the requirements of this manual. However, these requirements shall not apply to the pole owner, when the pole owner adheres to the NESC.

Formatted: Highlight

### 8.3 OVERLASHING

All aerial runs of fiber in Licensee's Fiber Optic Network shall minimize the use of slack fiber to no more than 100 feet per 1000' of cable and any such slack fiber shall be mounted to the adjacent pole or temporarily on the strand using strand mount snow shoes for no longer than 60 days during installation of the applicable Facilities. Licensee shall comply with Tucson Code Section 7B-15 for use, rental or lease of utility poles for aerial runs of fiber and shall remove such aerial runs within 90 days of said utility permanently removing their facilities from the applicable pole.

## 9. SUBMITTAL REQUIREMENTS FOR ALL UTILITY WORK

### DESIGN DOCUMENTS

The Utility Company must provide design drawings prepared by professionals in their respective field that depict the utilities and street infrastructure correctly including driveways, bus stops, landscaping, existing trees or vegetation, and sidewalks. The professional assigned by the utility company to prepare the drawings, will be responsible, on behalf of the utility company to ensure that all work is done in accordance with the latest PAG Standard Specifications and City of Tucson requirements. Here are some general design coordination items to address:

1. Work to be done in street corridors planned for expansion shall be coordinated with pending capital project plan designs for horizontal and vertical locations of proposed relocations.
2. Barricade plans shall be prepared by an ATSSA certified specialist and include all mobility impacts planning for safe travel through the construction zone.
3. Existing utility locations shall be investigated for depth at crossings through pothole or record drawing information in advance to avoid conflicts and delays during construction.



## CITY OF TUCSON PUBLIC UTILITY ADMINISTRATIVE MANUAL

- Existing plants and trees to be impacted shall be evaluated for protection or replacement.
- All existing conditions shall be replaced to at least the original condition or better as described herein.

Plans and supporting documents may be submitted to the following address for review:

[DOT-Engineering-Review-Section@tucsonaz.gov](mailto:DOT-Engineering-Review-Section@tucsonaz.gov)

### 9.1 CONSTRUCTION PLAN REQUIREMENTS

#### 9.1.1 Plan View Requirements (all utilities above or below ground)

The plan view shall include, but not be limited to, the following:

- Provide a scale or dimension adequate to accurately depict relationships among the physical features within the construction area and to identify potential conflicts. **Scale should be no smaller than 1" = 100 feet for overhead projects and 1" = 40' for underground'.**
- Make sure the existing and proposed rights-of-way and adjacent easements clearly labeled and dimensioned. Right-of-way lines shall be labeled "R/W" or "ROW."
- Show the location and size of all existing and proposed facilities and street improvements that the proposed utility construction would either cross or run parallel within the limits of the right-of-way corridor and the adjacent easement. The lip of gutter and/or edge of pavement shall be indicated when proposed construction is located within the asphalt surface and in relation to the right-of-way.
- Show all existing or proposed improvements including landscaping, above and underground structures, lip-of-gutter, curb, back of sidewalk, and front of sidewalk if not adjacent to the curb when proposed construction is located within an alley or behind curb and gutter.
- Show all existing and proposed paving, **including pavement patching.**
- Storm drains, sanitary sewer lines, and water lines over 12-inches in diameter shall be drawn to scale. Vertical poles over 12-inches in diameter shall be drawn to scale.
- All conduits or conduit systems over 12-inches in diameter **or in widthwise** shall be shown to scale if proposed construction is within 2-feet of existing conduit system.
- Provide a dimension that accurately describes all proposed utility crossings (underground and overhead) **when measured at a 90-degree angle, plus or minus 10 degrees or parallel with intersecting road.**
- Show the locations and limits of the proposed construction and their relation between other agencies or right-of-way owners. Add the jurisdiction name (ie. City of Tucson, ADOT, etc.).
- For infrastructure requiring new utility service, horizontal and/or vertical runs of electric power, fiber optic cable or conduit from the closest splice or interchange. If additional permits are contemplated for electric or fiber optic cable installation, said permits shall be referenced on the plan set, even if only proposed at the time of application.**
- Provide dimensions **between** ~~for~~ survey monuments located at the nearest cross street when the road is uncurbed. Dimension ties to ~~these~~ monument lines (not centerline of asphalt) in streets and to property lines in alleys and easements **to determine the offset position.**

Formatted: Highlight

Formatted: Highlight

Formatted: Highlight

Formatted: Highlight

Formatted: Highlight

Formatted: Highlight

Formatted: Highlight

**Commented [DJ15]:** TEP requests clarification on what is required? Dimensions for the horizontal control and surveying information or dimensions for survey ties for each pole/piece of equipment

Formatted: Highlight

Formatted: Highlight

Formatted: Highlight



## CITY OF TUCSON PUBLIC UTILITY ADMINISTRATIVE MANUAL

12. Show all existing topography affected by the proposed construction **if it may affect the vertical elevation or depth of a utility installation**. Vertical changes in elevation adjacent to vertical or exposed infrastructure may require retaining structures.
13. Provide a completed title block.
14. Provide a vicinity map indicating major cross streets.
15. Include a North arrow on each plan sheet. Orient the layout so North is either at the top or the left on the page.
16. Label all street names.
17. Provide a legend showing all symbology used on plans.
18. Show approximate floodplain or local flood limits.
19. Include a note stating, "Notify Arizona 811 two working days before construction." Call 811 or 1-800-782-5348.
20. All minor revisions to approved plans must be made distinctive on the revised plans by crossing out the original note, symbol, or value and replacing it with the revised information. Major revisions shall be indicated by "Clouded" symbol containing the new design information.

Formatted: Highlight

Formatted: Highlight

### 9.1.2 Profile Requirements (when utilities are underground)

The profile shall include, but not be limited to, the following:

1. Existing and proposed grades should be at intervals of ~~100-feet'~~ or less in the same alignment as the proposed construction. The profile shall be shown as a continuous line on the plans throughout the project.
2. Show all existing facilities that the proposed utility will cross (storm drains, sanitary sewer lines, waterlines, and conduit systems).
3. Storm drains, sanitary sewer lines, and water lines over ~~12-inch"~~ in diameter shall be drawn to scale. NOTE: All conduit systems over ~~12-inch"~~ in diameter or ~~width high~~ shall be shown to scale if proposed construction is within ~~2-feet'~~ of another existing conduit system.
4. Provide a vertical scale that adequately depicts installation of existing facilities. Please specify scale (i.e., ~~1-inch" = 2-feet'~~, ~~1-inch" = -feet5'~~, etc.)
5. Elevations shall be City of Tucson datum and indicated on the plans.



Commented [DJ16]: Utility companies do not know where other utilities are located and therefore we propose to remove this requirement

NOTE: Complete profile drawings showing all intersections return curve to return curve for Major

Figure 6 – Excess Overlashing





## CITY OF TUCSON PUBLIC UTILITY ADMINISTRATIVE MANUAL

Street to Major Street, or Major Street to Collector Street shall be provided when proposed construction crosses existing or proposed facilities. Profiles may also be required when clarity of a proposed crossing is necessary.

### 9.2 OVERHEAD INSTALLATIONS, RELOCATIONS, AND MAINTENANCE REQUIREMENTS

1. Minimum overhead clearance shall be 18-feet over street pavement and alleys. Overhead lines shall not obstruct or interfere with traffic signal visibility. Indicate the heights on the plans.
2. Existing underground facilities need not be shown on plans for overhead installations or maintenance (including overlashing) unless excavations are also included in the work. Overlashing expectations are described in the License Agreement for each respective utility.
3. Permits for overhead lines must comply with any License Agreement with licensed and franchised companies.
4. When plans are submitted for utility pole relocation (s) and/or removal (s), all utility owners that may be attached to the pole (s) will be issued a joint use utility permit. All pole occupants must relocate their facilities within 90 days of pole relocation. City will bill holdovers for the cost of removal plus 15% administrative costs. When all attachments are clear, the pole (s) shall be removed immediately before the permit is closed out.
5. Guy wires must be out of the pedestrian path.

### 9.3 MOBILITY CONTROL PLAN

A mobility control plan is required with right of way permit applications for all work proposed on arterial streets and collector streets. MCP's are not necessary with the right of way application for work in the residential areas; however, a MCP will be reviewed in the field at the preconstruction meeting.

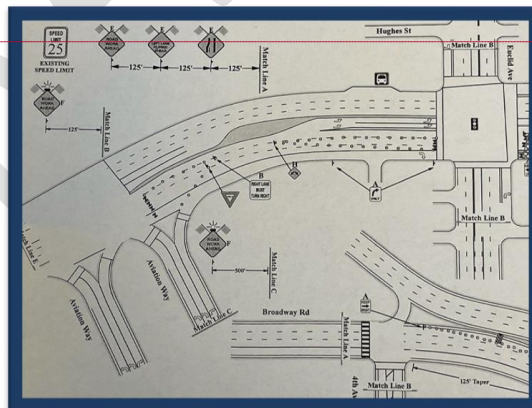

Formatted: Highlight

Formatted: Highlight

The City of Tucson governs all street, sidewalk, and alley restrictions. Traffic control devices utilized in the right-of-way must include provisions for all modes of transportation and accessibility. All work must comply with the requirements of the Manual of Uniform Traffic Control Devices (**MUTCD**) and current Additions By The City Of Tucson To The Manual On Uniform Traffic Control Devices For Temporary Traffic Control supplement.



## CITY OF TUCSON PUBLIC UTILITY ADMINISTRATIVE MANUAL

Please follow the CHECKLIST below when preparing and planning all work within the ROW. Lack of consideration for the different modes of transportation may affect the amount of time needed to review and respond to permit applications. Blue "Business Access" signs shall be required for construction affecting business access.

### 9.3.1 Mobility Control Plan Information **Required**

1. A plan view of the area to be barricaded. The plan should be situated so that North is up.
2. Must have a north arrow.
3. All streets must be labeled.
4. All intersections shown.
5. All side streets and alleys must be shown and labeled by name and if an alley as "alley."
6. All driveways must be shown.
7. Dimension current lane widths.
8. Show all bus stops.
9. Label or depict barricades, devices, and signs to be used respectively.
10. Indicate respective spacing of signs and barricades.
11. Show face of barricade direction.
12. Dimension width of area to be reserved/used for the work and restrictions.
13. Show all tapers and lengths.
14. Provide double sided blue "business access" signs at all business driveways.
15. Depict provisions for pedestrians.
16. Depict provisions for bicyclists.
17. Depict provisions for bus riders.
18. Provide barricade setup and takedown hours if it is not a 24-hr set up hours.



NOTE: Pedestrian provisions must be made through the construction site for all arterial and collector streets. Provisions for transit riders must be made and shown on the MCP. Bicycles can be directed to travel lanes provided the appropriate speed limit reductions are included and share road signs provided.

If the barricade plan is for multiple location set up, the entire project must be submitted for analysis and review. Staff will work with the Utility Company to modify the proposed plan provided it meets the minimum requirements set forth by this checklist and the MUTCD.

**Commented [DJ17]:** These requirements are overly restrictive and would result in delays of projects

## CITY OF TUCSON PUBLIC UTILITY ADMINISTRATIVE MANUAL

### 9.4 DRAINAGE/FLOODPLAIN

The permittee is responsible for ensuring the natural drainage is not impeded during and after construction.

City streets are used to convey stormwater drainage. Many local streets are jurisdictional floodways in nature and carrying at least 100-cfs in the right-of-way during the 100-year storm event. All infrastructure, above ground or below ground, proposed in a regulated floodplain shall require a floodplain-use permit. The Applicant is referred to Chapter 26 Floodplain and Stormwater of the Tucson City Code.

Design calculations for scour depth and a description of measures to be taken during and as part of the improvements must be provided for review and approval when crossing washes and crossings. Impacts to major wash bank protection shall require Pima County Flood Control approval and inspection.

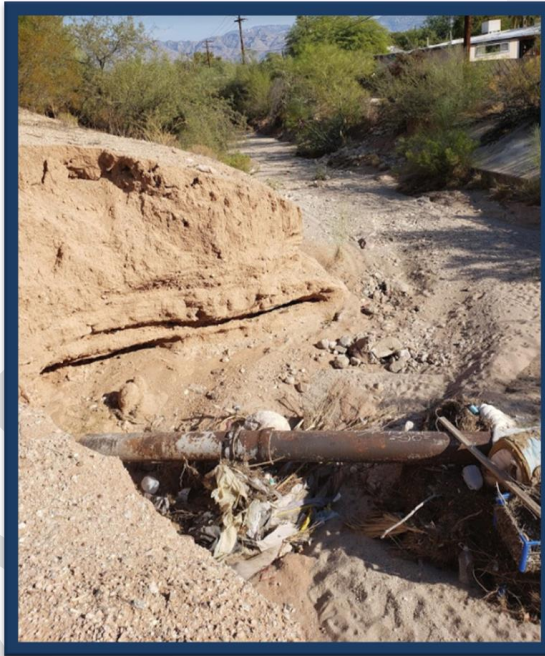

**FIGURE 8 Erosion Exposure**

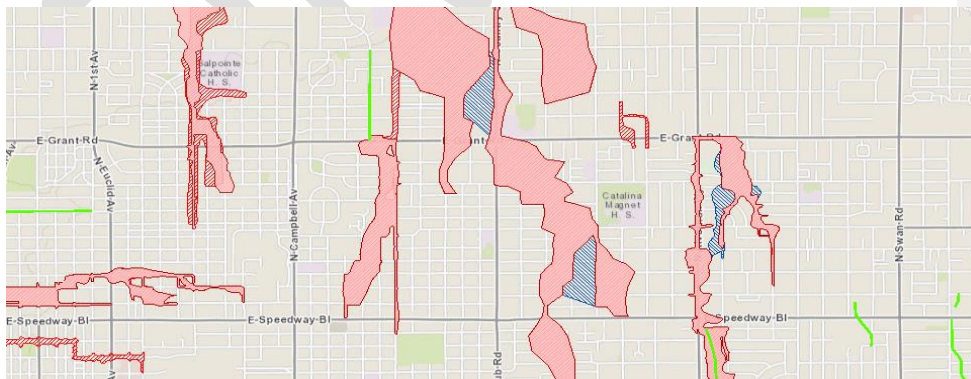

**Figure 9 – Sample Local Floodplain Layer (Map Tucson)**

# CITY OF TUCSON PUBLIC UTILITY ADMINISTRATIVE MANUAL

## 9.5 UTILITY REVIEW

The designer shall contact the neighboring utilities affected for **depth (when applicable)** and location. Conflict resolution **should will** be made before submitting to DTM for review and processing. Utilities to review include:

Formatted: Highlight

Formatted: Highlight

- Electric Lines (Tucson Electric Power)
- Potable and Reclaimed Water (Tucson Water)
- Sanitary sewer (Pima County Regional Wastewater Reclamation Department)
- Natural gas (Southwest Gas)
- Telecommunications (various fiber and cable)
- Traffic Signal and Street Lighting (City of Tucson)
- Drainage (Pima County Flood Control District and City of Tucson)
- Landscape irrigation (City of Tucson)
- Storm drain (City of Tucson)

Plans shall indicate the degree of accuracy and provide confirmation that other utilities have been **accounted for to the best of the company's knowledge, consulted with and agree with the proposed placement of the new infrastructure.**

Formatted: Highlight

### 9.5.1 Protection of Utility Service Connections Required

The designer shall also identify all business and private services to buildings and properties. The plans shall include notes to advise the Utility ~~Company to~~ Company to locate all house or business utility service connections along the property frontages affected. All house or business service connections shall be identified before new installation of utility lines are installed whether it be by trenching or jack and bore methods. The record drawings shall identify the locations confirmed or found in the field.

**Repair of the pavement disturbed, replacement of the landscape, and restoration of sidewalk or hardscape shall be included as part of the work description on the ROW Permit Application.**

Formatted: Highlight

Formatted: Highlight

## 9.6 COORDINATION

### 9.6.1 State Historical Preservation Office (SHPO)

Historic review, archeological review, and monitoring requirements may be required as part of the application. Check for location at the Historic Preservation layer on Map Tucson <https://maps2.tucsonaz.gov/Html5Viewer/?viewer=maptucson>

The Utility Company must provide confirmation of any monitoring requirements needed for the work to be done in an archeological sensitive area. This MUST be discussed with the Inspector at



## CITY OF TUCSON PUBLIC UTILITY ADMINISTRATIVE MANUAL

the Preconstruction meeting if it is a requirement of the ROW Permit or in a known archeologically sensitive area.

### 9.6.2 ADOT or Other Agencies Impacted

Work being done near a railroad **Union Pacific Rail Road (UPRR)**, the freeway, or other State regulated roadways may need their own separate permit. The designer will need to determine if any work will enter the jurisdiction's ROW including the barricade footprint. A separate ADOT, UPRR, Pima County, or other agency ROW Permit will be required if there is encroachment, and the permit must be secured by the Applicant.

Commented [SC18]: Spell out in list of abbreviations...see my prior comment about creating a list of abbreviations.

Formatted: Highlight

Formatted: Highlight

### 9.7 NATIVE PLANT PRESERVATION PLAN (NPPP)

All plans must depict any trees or bushes growing in the construction zone, consistent with UDC Section 7.7.4. Impacts to the vegetation must be addressed before, during, and after construction in accordance with these requirements and current City Ordinances. No damage to said trees shall occur without provisions for mitigation, pruning, or replacement as described in Section 10.13.

Formatted: Highlight

### 9.8 STORMWATER POLLUTION PROTECTION PLAN (SWPPP)



Storm water management within the construction site is the responsibility of the permittee. Where required, the permittee shall obtain all necessary National Pollution Discharge Elimination System (NPDES) permits <https://azdeq.gov/mydeq> and comply with all applicable requirements therein. The need to obtain this permit is dependent on the use of ROW area for equipment staging, materials staging, disturbance to ground areas by equipment routes in the construction zone. A Notice of Termination (NOT) will be necessary before the project is closed out.

For project sites less than one acre that are occupied and disturbed by construction or maintenance activity, work shall follow best management practices for site housekeeping.

### 9.9 ~~SUN LINK STREETCAR (SLS)~~ UTILITY COORDINATION

All utility company work located within the Modern Streetcar corridor that is in the public rights-of-way, must also be reviewed and approved and a Track Access Permit issued by Sun Link for any street having MSC track and overhead power. The Modern Streetcar corridor within the public rights-of-way is defined as 5-feet from the outside of guideway curbs over which this transit route operates.

Commented [SC19]: Please replace "Modern Streetcar" with "Sun Link Streetcar" in all places.

[https://www.tucsonaz.gov/files/transportation/SOP\\_101\\_13\\_Rev03\\_Track\\_Access\\_Request\\_20160511.pdf](https://www.tucsonaz.gov/files/transportation/SOP_101_13_Rev03_Track_Access_Request_20160511.pdf)



## CITY OF TUCSON PUBLIC UTILITY ADMINISTRATIVE MANUAL

Work near or around the overhead power lines may require a de-energizing of the MSC powerlines and work will need to be done at night. Coordination of this requirement will be included in the ROW Permit application.



Commented [SC20]: Can we see if Sun Link has a better photo...

Figure 10 – Modern Streetcar

### 9.10 SPECIAL CONSIDERATIONS

#### 9.10.1 Downtown

Special consideration should be given when planning the upgrade and installation of wet or dry utilities downtown. Many of the downtown streets contain a concrete layer under the pavement. Special patching requirements and limits shall apply to improve the appearance of downtown streets to like new condition regardless of the street's age or appearance.

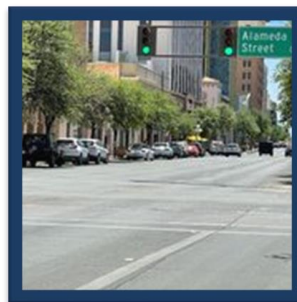

## CITY OF TUCSON PUBLIC UTILITY ADMINISTRATIVE MANUAL

### 9.10.2 Sight Visibility Triangle (SVT)

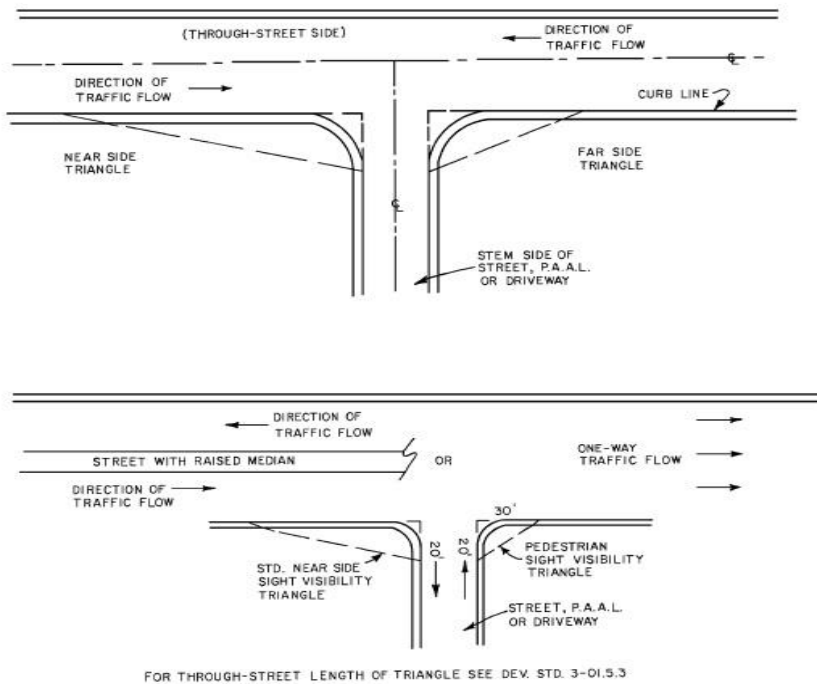

Poles, equipment, or other above ground infrastructure shall be placed so as not to obscure any portion of any Sight Visibility Triangle (SVT), consistent with the City of Tucson Unified Development Code (UDC) Sections 10-01.5.0 – 10-01.5.4 (Sight Visibility). Any deviation from this requirement requires approval from the City of Tucson through the Utility Waiver Request process.

Formatted: Highlight



## CITY OF TUCSON PUBLIC UTILITY ADMINISTRATIVE MANUAL

### 9.10.3 Vaults

It may be necessary to construct a vault within the street ROW at locations where major intersection of power or communication systems occur. Vaults may be used at these locations provided there are no other locations possible. They will be allowed ~~to be~~ under the paved section of the road and made compatible with other utilities that are present. A vault constructed under pavement must be traffic rated to withstand the expected traffic volume loadings. The vault must be design and constructed to sustain H20 loading (minimum) as defined by the Federal Highway Administration.

The utility company will be responsible to adjust the vault elevation in the pavement should the City of Tucson add a pavement overlay or modify the street profile that causes an elevation change at this location.

### 9.10.4 Pole Placement

New electrical or communication poles shall be placed within 1'-3' of the ROW/property line (if practicable). Additionally, new poles shall not be placed within five (5) feet of the perpendicular extension of the ROW-facing façade of any single or multifamily dwelling unit (if practicable). The perpendicular extension shall be derived by drawing a straight line following the roofline on each side of the façade to and through the ROW. Service poles for private use shall be on private property only. Individual service poles shall be reduced and eliminated where possible by moving overhead service lines to compatible underground locations.

New utility poles, ~~street light~~streetlight poles, power poles, or wireless support structures shall be a minimum 150 feet from an existing verticality **unless approved by a Utility Waiver Request.**

Streetlight poles or dusk to dawn poles shall additionally be spaced based upon safety lighting design requirements. All lighting must be LED and must meet City of Tucson and Pima County Outdoor Lighting Code and UDC standards.



Formatted: Highlight

### 9.10.5 Meters, Services, and Pedestals





## CITY OF TUCSON PUBLIC UTILITY ADMINISTRATIVE MANUAL

Meters, controllers, and meter pedestals shall be located strategically so to limit their placement not be in the SVT, where possible, in arterial or collector rights-of-way.

It is the intent to place meters, controllers, and meter pedestals at locations other than in front of homes or within pedestrian pathways in residential areas. This may be accomplished by locating them in alleys, easements, or near drainageways unless screened to meet the intent of this direction.

Formatted: Highlight

Formatted: Highlight

Power to a streetlight or SWF may be extended within the ROW from the nearest available power source for poles having streetlights.

Underground electrical services for irrigation for private use shall not exceed 100-ft in the public ROW without a temporary revocable easement from the City of Tucson and special protective design requirements prescribed by the department. Electric services for public equipment shall be designed and conductors sized in accordance with applicable codes.

### 9.10.6 Pullboxes

Pullboxes should be placed outside of existing or future pedestrian paths where possible. If the existing ROW is not wide enough or there are other obstructions that may prevent this, the pullbox may be in the pedestrian path provided it is flush with the ground and is within a concrete collar that will help support it from settling.



All pullboxes located in alleys or streets shall use a traffic rated design and made of materials to withstand H20 traffic loading.

### 9.10.7 Specialized Location Markers

Markers identifying the location of underground infrastructure shall be limited to low profile style markers that are flush with the ground. The use of location markers must be shown on the plans and approved.



Use of vertical identification markers might be considered in rural locations where utilities are difficult to identify as being present.

Formatted: Highlight



## CITY OF TUCSON PUBLIC UTILITY ADMINISTRATIVE MANUAL

### 9.10.8 Alley Clearance

Meters or above ground splice closures shall be screened where possible in residential areas. Placement of screens, poles, meters, or pedestals in alleys shall be placed with clearance in mind so to allow for Solid Waste Collection equipment and vehicles.

Residential alleys are typically 20-ft across but may be as little as 16-ft wide. Trucks vary in width and may be as much as 8-feet wide at the wheels. Containers vary in diameter but are

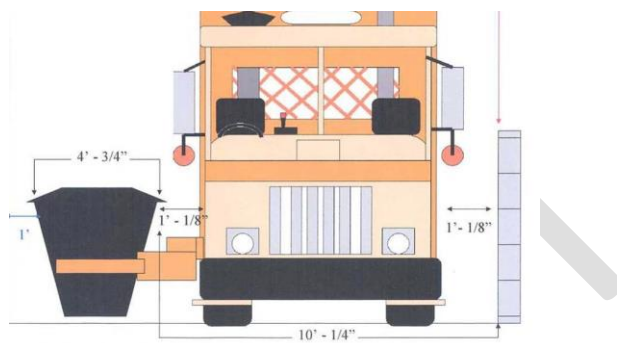

Figure 14 – Solid Waste Equipment Clearance

as wide as 4-ft across the top. Above ground accessory structures that are installed or extend into the alley must be checked to ensure their location can provide passage of refuse collection trucks and utility equipment traffic.

### 9.11 FACILITY ATTACHMENTS TO BRIDGES OR ROADWAY STRUCTURES

Communication or electric power facilities may be installed as attachments to bridges or roadway structures only where the utility company has demonstrated that all other means of installation is not practicable. Other means shall include, but are not limited to, underground and independent poles and only if made aesthetically pleasing. Most new bridge designs include empty conduits for this purpose. Special negotiations and lease of the conduit may be necessary.

If an above ground attachment must be made, submittals shall include sealed plans, profiles, and details on the proposed attachment to the structure and method of attachment, along with sealed structural calculations for all brackets and connection devices into the structure. An Arizona Registered Structural Engineer must seal the plans and calculations. **This shall apply for each new attachment request not considered by the previously approved analysis.**

**Commented [DJ21]:** TEP requests clarification, does the attacher need to the stamped plan or the bridge engineer?

**Formatted:** Highlight

WET utilities carry a significant added weight and will be discouraged from attaching to a bridge or structure unless the requesting Utility Company is willing to pay for the added costs necessary to support the loading; make the installation aesthetically pleasing; and address access



## CITY OF TUCSON PUBLIC UTILITY ADMINISTRATIVE MANUAL

requirements necessary to do maintenance to its own respective infrastructure without significantly affecting traffic capacity. Requests will be considered on a case-by-case basis.

Facility installations conveying commodities that are volatile, flammable, corrosive, or present high degrees of risk to persons and property in the event of damage to or failure of that facility is highly discouraged but may be reviewed and approved on a case-by-case basis.

### 10.CONSTRUCTION AND MATERIAL REPLACEMENT EXPECTATIONS

The City of Tucson must coordinate new work and manage the use of the ROW to protect its own infrastructure. This may include but not be limited to paving, sidewalk, curb, traffic signals, street lighting, signage, landscaping, and storm drainage. The condition of the City's infrastructure must be maintained, replaced, or improved as part of any activity within the public ROW.

The standards and requirements for street pavements are described in the City of Tucson Unified Development Code Technical Standards Manual per Ordinance 11025 and Ordinance 8727. The requirements in Section 10- Transportation provide direction to reviewers and give expectations to utility companies for the repair of pavements caused by the installation of utility infrastructure in street rights of way. The two documents shall serve to complement one another. Should differences exist between them, the more stringent requirement shall be required and enforced.

Utility Companies are required to complete their pavement restoration work unless a cost sharing agreement is executed listing the cost, payment schedule, and expectations of parties to restore the street to a better condition in accordance with Chapter 25 of the City Code.

Formatted: Font: Not Bold, Highlight

Formatted: Highlight

Formatted: Highlight

Formatted: Highlight

Formatted: Highlight

Formatted: Font: Not Bold

Formatted: Indent: Left: 0.1"

#### 10.1 SHADING

Shading shall extend to one foot above the top of the highest projection of the facility being installed and conform to the parent organization's specifications.

#### 10.2 BACKFILL

##### 10.2.1 Non-Paved Areas

Backfill in non-paved areas may be replaced with native material compacted to a minimum 85-percent of the material's maximum density.

##### 10.2.2 Under Pavement

Backfill under pavement is important to the integrity of a pavement patch. The City of Tucson has determined that the failure of most patches begins with poor workmanship and the type of backfill material used to backfill trenches or other excavations. Regardless of the age and



## CITY OF TUCSON PUBLIC UTILITY ADMINISTRATIVE MANUAL

condition of the pavement, the following will be required of all disturbance to existing pavement in streets or bike path areas:

Trenches and excavations shall be void of native soils and the backfill of trenches for utility mains or services under asphalt concrete (AC) shall be made with aggregate base (AB) material that meets current Pima Association of Governments (PAG) Standards and specifications. The aggregate base AB must be compacted to 100-percent of the respective material maximum density. Density tests shall be made by a certified material testing laboratory. A minimum of one test per day is required and depending on the length of work, more tests may be necessary. A density test shall be taken ~~for~~ each day work occurs and for every 100-CY of material compacted. The results shall be reported to the City's Inspector and included in the ROW Permit closeout.

### 10.2.3 Concrete Caps or Encasement

A 6-inch concrete cap or concrete encasement of the conduit shall be used as required under Section 8 for utilities installed underground that have less than 24-inches of cover.

Formatted: Highlight

## 10.3 PAVEMENT PATCH

### 10.3.1 Moratorium

The City of Tucson has established a no cut pavement moratorium for new pavements and pavement rehabilitation projects. Information as to which streets and their locations that special restrictions apply may be found at



<https://maps2.tucsonaz.gov/Html5Viewer/?viewer=maptucson>  
or at <https://www.tucsonaz.gov/apps/moratorium/>

### 10.3.2 Emergencies or New Service Lines

Service line repairs may be made in new pavements without a moratorium patch requirement provided the backfill and pavement repair includes NO native backfill and the pavement area affected is less than 4-ft wide to complete the T-Top Patch Detail. If the width exceeds the 4-ft maximum width, the area of patch must comply with moratorium patch requirements.

### 10.3.3 Moratorium Pavement Repair

Pavement patch limits for pavements under moratorium is a T-Top Pavement patch, 2550-ft beyond the limits of the trench on both sides of the excavation and for the width of the lane affected. See Exhibit C.

Formatted: Highlight



## CITY OF TUCSON PUBLIC UTILITY ADMINISTRATIVE MANUAL

### 10.3.4 Non-moratorium Pavement Repair

Pavement patch limits for pavements not under moratorium shall follow a T-Top Detail, see **Exhibit A**. The Utility Company shall apply an approved microsurface treatment to the affected patch area for 25--ft beyond the trench limits and for the width of the lane affected on the street disturbed for the street affected.

Formatted: Highlight

Formatted: Highlight

### 10.3.5 Multiple cuts

Multiple cuts means more than one. If multiple cuts and patches are made to the same street and within the existing pavement, the street surface for the duration of the cuts and patches shall be milled 2-inches and overlaid with 2-inches of a City approved asphalt mix on arterial and collector streets.

Formatted: Highlight

For residential streets, if multiple cuts are made to the same street and within the same block (intersection to intersection), a microsurface treatment shall be added to the surface of the patched area for the entire width of lane affected between cuts upon completion of the pavement patch in lieu of a mill and overlay. In residential areas, the treatment shall extend to the center of the street. If both sides of the street have been cut, the entire street shall be covered over between the limits of the first cut to the last cut on the same respective street.

Commented [DJ22]: What does this mean?

## 10.4 DOWNTOWN STREETS PAVEMENT REPLACEMENT REQUIREMENTS

All downtown streets affected by a pavement cut shall be resurfaced by milling and replacing the pavement in the lane affected. The depth of the mill and pavement replacement shall be 2-inches thick and 2550-ft in both directions from the edge of the pavement patch method used.

## 10.5 LOCATION OF UTILITIES, IRRIGATION LINES, AND HOUSE SERVICE CONNECTIONS

Potholes are required to locate existing utilities, irrigation lines, and house service connection locations. Most utility line locations may be determined with electronic measuring devices. House service connection information might not be available. Vacuum extraction is often used, but the pavement must be disturbed to extract the soil. Pavements shall be patched upon determining or verifying the desired utility service connection information or status.



New pavement (under moratorium) may be cored for potholes and replaced per **Exhibit B** provided a flat, vertical surface is maintained and left in place upon completion of its repair. Pavements older than 5-years shall be treated as a patch and resurfaced with the materials and for the areas described in 10.3.5 herein.

Formatted: Highlight



## CITY OF TUCSON PUBLIC UTILITY ADMINISTRATIVE MANUAL

### 10.6 BORE PITS

Bore pits in the pavement and potholes made on older pavement shall be repaired per the pavement patching direction described in Section 10.3.3 or 10.3.5 where applicable herein. The location of all services and utility lines that are expected to be encountered as part of the operation, must be identified and located in the field to meet **AZ 811** requirement. The Applicant must show them on the plans, where possible, and this work described in the scope of work for the ROW Permit. Repair of damaged pavement for bore pits or potholes shall be made as described in 10.3.5 herein for pavement patches.

Formatted: Highlight

Formatted: Highlight

Formatted: Highlight

### 10.7 SAWCUT AND MILL

Any excavation into Portland Cement (PC) concrete or asphaltic concrete (AC) pavement shall either be cored or sawcut to provide a face to join the new PC concrete or asphaltic concrete material together. For pavement replacements that require milling, the edges shall be sawcut and the edge made smooth to tack and join the old to the new material.

### 10.8 CONCRETE CURB REPAIRS

Concrete curbs that are damaged by truck tires or other heavy equipment shall be replaced by first saw cutting the curb at the nearest joint. The Utility Company shall be careful to not remove beyond 2-inches of the pavement adjacent to the curb. Broken pavement or a sawcut beyond 2-inches shall follow the pavement patching direction described herein.

### 10.9 CONCRETE SIDEWALK OR HARDSCAPE REPLACEMENT

Concrete Sidewalks that must be removed, damaged by the utility installation or for maintenance shall first be sawcut at the nearest joint. The sidewalk shall have a minimum thickness of 4-inches and a minimum thickness of 6-inches is required in driveway areas. Construction expansion joint material shall be provided on both sides of the sidewalk match and extend vertically the entire depth of the sidewalk face.

Where concrete tint or integral color are necessary, the Utility Company shall match the current color as closely as possible for the area impacted.

Formatted: Highlight



### 10.10 AZ 811 MARKINGS REMOVAL

Painted AZ 811 utility location markings for the work performed shall be removed from all locations outside of the ~~street pavement~~street pavement. This includes concrete sidewalk, curb, and landscape areas—within areas within 30-days of completing work requiring said marking information. The site shall not be deemed complete and restored until the requested markings for the project have been removed to the Inspector's satisfaction.

Formatted: Highlight

Formatted: Highlight

Formatted: Highlight

Formatted: Highlight



## CITY OF TUCSON PUBLIC UTILITY ADMINISTRATIVE MANUAL

### 10.11 STRIPING OBLITERATION/INTERRUPTION

All striping that is interrupted by pavement patching shall be replaced in kind.

### 10.12 LANDSCAPE IRRIGATION AND GROUNDCOVER REPLACEMENT

Landscaping within the public ROW may have some additional requirements and coordination. Irrigation lines under new or modified driveways will be required to be sleeved before rebuilding the existing improvements.

Groundcover shall be replaced in kind to match. Decomposed granite (DG) used for ground cover, and rock plating shall be replaced to its original thickness and DG shall be no less than 2-inches over the top of newly excavated and compacted area. Rock plating shall have a thickness of at least 1.5 times the average diameter of the rock disturbed.

DO NOT replace the cover material with contaminated, blended, material set aside before construction unless it can be kept from blending with the soil underneath. Protected DG, new DG, or other decorative rock cover will need to be used that matches most closely in color. The ROW Inspector will determine if it is too contaminated to reuse.

### 10.13 TREE REPLACEMENT AND/OR PRUNING

Trees and shrubs that are removed shall be replaced in kind and watered for a period of 6-months. Existing irrigation systems may be repaired and modified with approval from the DTM representative and used where possible. Where none exist, the watering schedule shall be as directed by the DTM Landscape Architect or designated representative. Failure to water and maintain resulting in the loss of the tree shall require another tree or shrub replacement and maintenance period.

Formatted: Font color: Auto, Highlight

Formatted: Font color: Auto, Highlight

Formatted: Font color: Auto

Trees that need to be pruned to allow room for equipment or to allow installation of infrastructure construction, shall be performed by a worker that is an arborist, certified by the International Society of Arboriculture. Certified Tree Workers under the supervision of an ISA Certified Arborist, may also perform the pruning.

### 10.14 ADA IMPACTS AND PLANNING



## CITY OF TUCSON PUBLIC UTILITY ADMINISTRATIVE MANUAL

The Utility Company shall modify all curb access ramps disturbed by the construction. Paving of the street disturbed may trigger curb access ramp modification. Pedestrian access ~~during construction~~ will need to be provided during construction.

No redirection of pedestrians on an arterial or collector street shall be allowed by the MCP. A traffic lane may need to be reserved/restricted to provide pedestrian access utilizing water or concrete barrier protection. A or temporary paved path (2-inch thick by 5-ft wide min). ~~Pavement detours may shall~~ be constructed through the construction zone to satisfy this requirement.



Formatted: Highlight

Formatted: Highlight

DRAFT





## CITY OF TUCSON PUBLIC UTILITY ADMINISTRATIVE MANUAL

### 10.15 OPEN EXCAVATION



All excavations shall be secured for safety and to provide pedestrian access after shift. Where pedestrian access is not possible, a separate pedestrian path shall be provided with the use of concrete or water barrier in the street and signed to allow safe use of the road. A temporary pavement ramp may be necessary to provide pedestrians the opportunity for a safe transition to access the new path elevation from the curb.

All open trenches shall be barricaded at a minimum and excavations may need to be covered by steel plates or approved materials in accordance with the City's Supplement to the MUTCD at the end of shift.

Formatted: Highlight

## 11. SWF DESIGN GUIDELINES AND STANDARDS

### 11.1 SMALL WIRELESS FACILITIES (SWF)

Small wireless facilities shall be designed and located to minimize the impact to homeowners and business owners and to maintain the character and appearance of the surrounding neighborhood. This will include lot line location, pole appearance/aesthetics, safety, pedestrian access, and compatibility with existing utility infrastructure. To that end, support equipment shall be minimized and above ground electric meters shall be included within the pole makeup where possible and at approved locations.



Commented [SC23]: This pictures are cutoff at the top...any way to include the whole pole? Maybe just use one photo?

### 11.2 POLE LOCATIONS AND SPACING CONSIDERATIONS

Companies installing SWF are encouraged to use existing power pole locations or replace existing streetlights with a dual-use (combination of small cell and street lighting) pole. Should this not be possible, freestanding poles, equipped with a mast arm and luminaire for potential street lighting shall be located to meet the ends described herein.

SWF poles shall not be spaced closer than 150-feet radially from one another unless approved by a Utility Waiver Request.

Commented [SC24]: Please double check all locations in the document for consistency...are we abbreviating "feet" or spelling out.

Formatted: Highlight



## CITY OF TUCSON PUBLIC UTILITY ADMINISTRATIVE MANUAL

Different or competing communication providers shall not space separate SWF poles within 150-feet of one another.

New SWF poles may not be closer than 150-feet from an existing utility pole unless approved through a Utility Waiver Request. The SWF design should attempt to replace existing verticality objects to meet this intent.

Formatted: Highlight

### 11.3 TYPES OF SMALL CELL WIRELESS FACILITIES

It is the intent to reduce the number of poles on a street and remove or position above ground equipment from view. To that end, four different types of small cell installations may be permitted in the rights-of-way. These types include the following concepts:

Formatted: Highlight

- Attachments to existing wooden power poles- Type 1,
- Attachments to wooden streetlight poles- Type 2
- Replacement of existing wood poles or metal streetlight poles Type 3, 3A, ~~3B~~
- New freestanding metal pole installations Type 4.

### 11.4 INTENT OF MINIMIZING THE ROW SPACE FOR EQUIPMENT

Colocation requires permission from the pole owner. The pole must be able to withstand the extra weight of colocation equipment, fiber installations, and wind loading. A structural analysis will be required.

Commented [SC25]: Please double check correct spelling and replace in all places. I believe its spelled "collocation"...but I could be wrong.

New steel and painted poles are desired to be used and will be required at locations where streetlights currently exist or where DTM wooden poles are located. Paint colors are described in Section 11.7 of this manual.

Formatted: Font: Bold, Highlight

Formatted: Font: Bold, Highlight

Formatted: Font: Bold, Highlight

Formatted: Highlight

Formatted: Highlight

Existing "Dusk-to-dawn" or steel street-light poles already have power and their auxiliary equipment in place. Power sharing agreements can be established more easily with these locations. Cellular providers are strongly encouraged to seek out and to use these locations first where possible.

Commented [SC26]: We might want to add this to the definitions page. Not all GCs are from Tucson and may not know what a "Dusk to Dawn" light is

Formatted: Highlight

Formatted: Highlight

Formatted: Highlight

Formatted: Highlight

Formatted: Highlight

Formatted: Highlight

Formatted: Highlight

New pole locations will have a lower acceptance by the community and may need some advanced outreach strategies. Potential locations include replacement of existing verticality such as other streetlight poles, dusk to dawn poles, or possibly existing traffic signs. The cellular provider is encouraged to minimize the number of above ground pieces of accessory equipment and include screening of the above ground equipment in residential areas.

All street lighting to be added or replaced must be 3000K LED and must meet all other requirements of the City of Tucson and Pima County Outdoor Lighting Code and UDC Standards.



# CITY OF TUCSON PUBLIC UTILITY ADMINISTRATIVE MANUAL

## 11.5 POLE TYPES

### 11.5.1 Type 1 Utility Pole Attachment

A Type 1 Utility Pole attachment is a collocation of SWF equipment on an existing power pole. The separation between power and any equipment shall meet the Power Company's separation guidelines to allow safe maintenance to all users.

Use of existing wood poles must first be approved by the pole owner.

#### Notes for poles owned by non-Power Company owned by a non-power company

- One equipment shroud, containing all required small cell equipment, shall be installed per pole. Exception: one additional equipment shroud may be allowed per pole if the antenna is located within the second equipment shroud.
- Strand Mounted Equipment Shroud- the size is limited as described by the AZ Revised Statutes (ARS) 9-506 for size and number of antennae allowed per location 9.0 cubic feet maximum strand mount equipment shroud. Only one equipment shroud shall be installed per permit location.
- Any meter housing shall be located outside of the pedestrian path to address pedestrian or vehicle accessibility requirements.

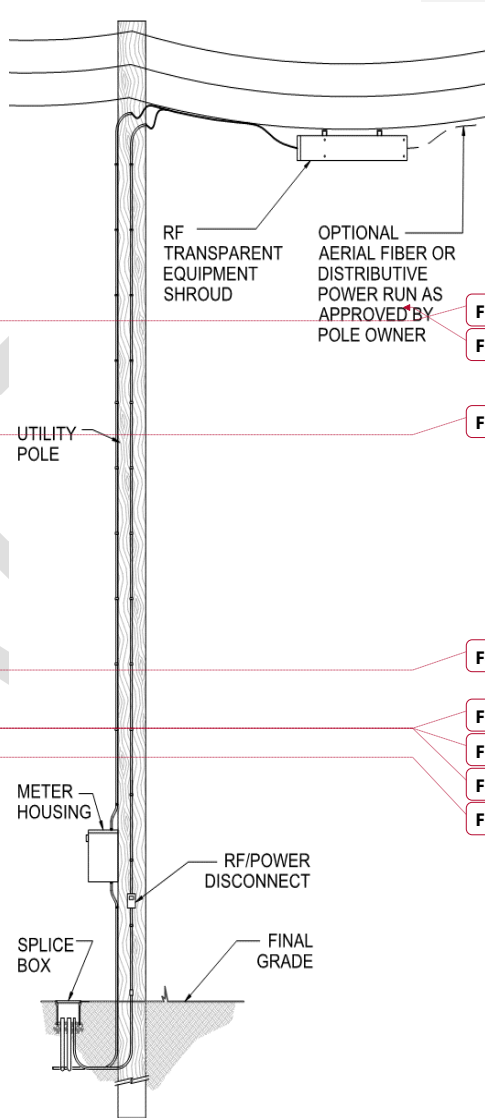

Figure 15 – Type 1 Pole

## CITY OF TUCSON PUBLIC UTILITY ADMINISTRATIVE MANUAL

### 11.5.2 Type 2- Attachment to Wooden Streetlight Pole

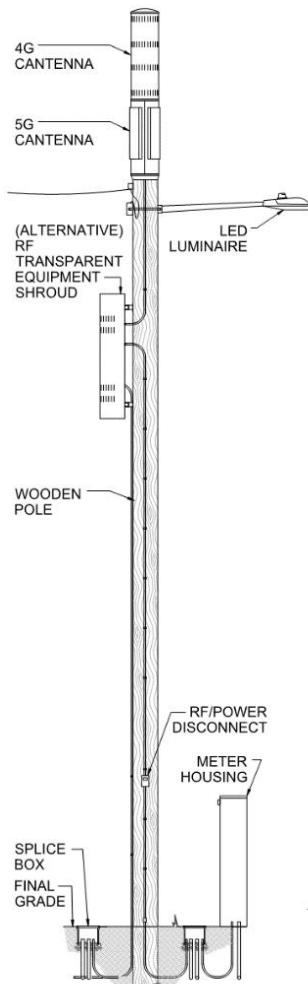

Figure 16 – Type 2 Pole

To maximize the use of existing pole conditions, a cellular provider might consider the use of pre-existing streetlights on wooden poles (such as a dusk to dawn light) as a viable location. The location will need to be reviewed for spacing and position consistency requirements described herein before proceeding.

Wooden poles having overhead fiberoptic lines and that are designated to be removed/relocated shall not be considered as a viable candidate for adding streetlights and SWF equipment.

If the wood pole needs to be lengthened, the pole shall be replaced with a painted steel pole, Type 3 with accessory equipment placed at strategic locations to meet the intent of this manual or a Type 3 with equipment internal to the pole.

An existing meter pedestal may remain. New meter pedestals will require location approval.

Power sharing shall be in accordance with established power sharing contract arrangements established with the City of Tucson.

New meter pedestals will require prior approval, at the City's sole discretion, upon a showing of necessity.

Power sharing, where available, may be requested by executing a Power Sharing Rider to the Wireless Right-of-Way and submitting with an approved Site License Agreement (SLA). Power sharing is permitted at the sole discretion of the City.

**Commented [JS27]:** Why is this still an option? I thought these wooden streetlight poles could not handle the additional load, plus we require all streetlight poles to be replaced by a small cell pole. Is the City changing its mind?

**Commented [DJ28]:** TEP would like to verify that these are City of Tucson owned poles

**Commented [MA29]:** Our standards do not allow for pole-mounted meters yet, but we hope to soon

**Commented [DJ30]:** TEP would like to understand how this will work from our perspective, what is the process for power sharing?

## CITY OF TUCSON PUBLIC UTILITY ADMINISTRATIVE MANUAL

### 11.5.3 Type 3 Combination Steel Pole (SWF and Light Pole)

A Type 3 Combination pole either replaces a streetlight pole or has the potential to provide street lighting capability in the future. Power sharing agreements apply in this instance.

A Type 3 small cell and streetlight pole may be located where an existing wooden or metal streetlight pole exists or at a new location strategically determined to provide the best cellular service. If a streetlight does not exist at a new, proposed location, the pole will be equipped and wired for a streetlight for potential future use of the light.

The Type 3 pole typically includes a concrete pole foundation, equipment cabinet, riser pole, luminaire, mast arm, luminaire control node, antenna or antenna enclosure, and all hardware and electrical equipment necessary for a complete assembly.

The metered pedestal location may be separate from the pole in arterial and collector locations unless these street classifications pass through a residential area. Accessory equipment should avoid landscape, pedestrian pathway, or sight triangle, as much as possible.

All small cell carrier equipment in residential areas shall be in alleys, drainageway, or other out of view locations where possible. If this cannot be done. The equipment must be screened and hidden behind an exterior shroud to maintain the best look of the neighborhood.

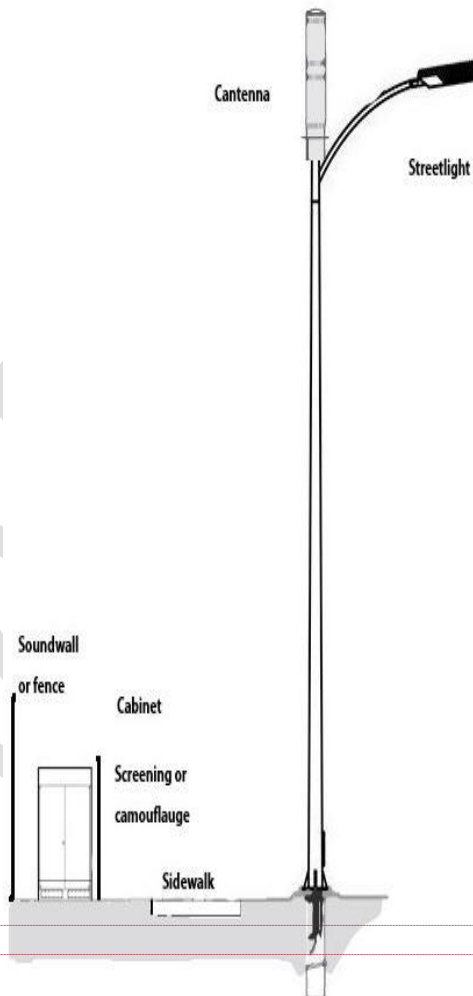

Formatted: Highlight

Formatted: Highlight

Figure 17 - Type 3 Pole

## CITY OF TUCSON PUBLIC UTILITY ADMINISTRATIVE MANUAL

### 11.5.4 TYPE 3A Steel Pole with Enclosed Meter

The Type 3A Pole is desired to meet the intent of reducing above ground equipment or obstructions. The feature of this pole is all small cell carrier equipment shall be housed internal to the pole or visibly screened / hidden behind an exterior shroud.

The Type 3A pole components shall be shaped to be visually pleasing and proportional to each other. They shall be painted to provide the best aesthetics to match the area they are located within. Directions on the color choices shall be given to the Utility Company during the pre-submittal process.

In locations where historical lighting architecture is required to be matched, the Utility Company shall match the architectural elements in style and color to the satisfaction of the community.

Type 3 combination poles should include a decorative transition over the base equipment cabinet upper bolts, hidden hardware connections, and a restriction of horizontal flat spaces greater than 1.5- inches to prevent cups, trash, and other objects from being placed on the pole components. Each pole component shall be architecturally compatible to create a cohesive aesthetic.

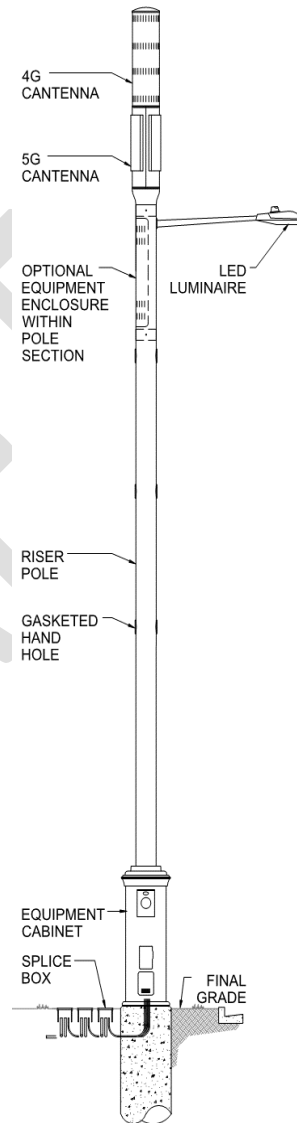

Figure 18 - Type 3A Pole

**CITY OF TUCSON PUBLIC UTILITY ADMINISTRATIVE MANUAL**

DRAFT



## CITY OF TUCSON PUBLIC UTILITY ADMINISTRATIVE MANUAL

### 11.5.5 Type ~~43B~~ Steel Combination Pole (with Additional Providers)

The Type 3 pole will be allowed when the equipment for two (2) separate providers is proposed to be installed on a single pole. To qualify for this permit, the Utility Company must demonstrate that proposed deployment(s) cannot be integrated into the equipment cabinet or the antenna.

This pole must be composed of a single equipment cabinet, riser pole, optional internal RF transparent section in the riser pole, streetlight, antenna, and a single externally mounted equipment shroud.

The exterior mounted equipment shroud shall match the pole aesthetics. Care should be taken to integrate the mounting attachments into the enclosure design.

The enclosure shall be securely strapped to the pole.

Wires and cabling shall be hidden from view. Cables and wires shall be located internal to the pole until they reach a cable grommet.

Weatherproof grommets shall be installed at all cable entry points. All pole openings shall be weatherproofed to prevent interior rusting of the pole.

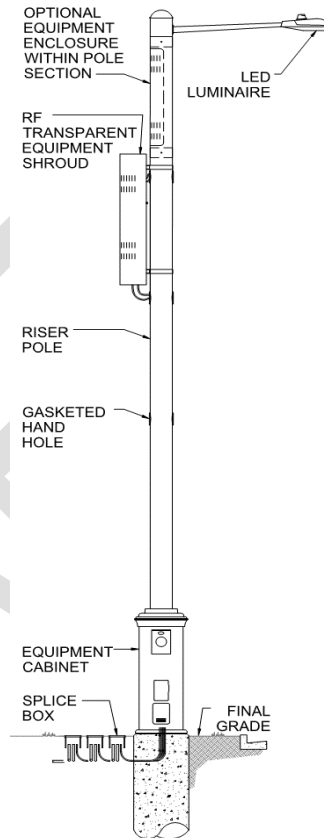

Figure 19 – Type 3B Pole



## CITY OF TUCSON PUBLIC UTILITY ADMINISTRATIVE MANUAL

### 11.6 ACCESSORY EQUIPMENT

All accessory equipment is desired to be contained within the SWF pole so to not add to the number of above ground obstructions that must be placed within the available right-of-way in support. If there is available space, and screening is approved, the small cell accessory equipment shall be placed in proximity to a common property line between adjoining residential properties, utility easement/alleys, alleys, or drainageway access roads. The intent is to hide or minimize visual impacts equitably among adjacent and nearby properties. Screening may be necessary if the locations do not meet the intent and screen color shall meet the neighborhood approval.

Accessory equipment is allowed on arterial and collector streets. Accessory equipment may be placed adjacent to a residential property located on a corner lot provided it is not in the SVT. If accessory equipment is restricted to midblock locations, the small cell facility shall be placed away from it so that a cluster of obstructions is not formed. A SWF pole may replace existing street signposts.

If these placement requirements are not technically feasible, the applicant may submit a [Utility Waiver Request](#) [SWF Waiver](#) to the City's Utility Coordinator requesting the small cell facility be exempt from these requirements and offer alternative locations reasonably meeting the intent of these standards and minimizing impacts among residential properties.

The location of replacement poles, new poles, and supporting equipment must comply with the Americans with Disabilities Act, city construction and sidewalk clearance standards, city ordinances, and state and federal laws and regulations to provide a clear and safe passage within the rights-of-way.

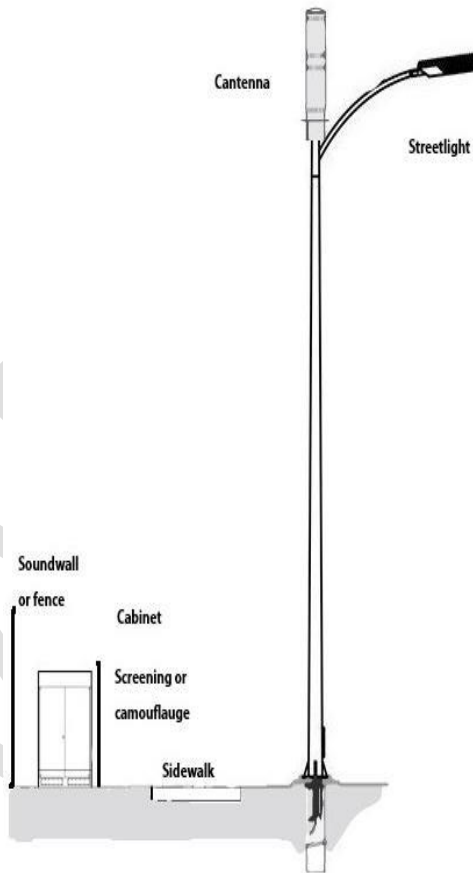

Figure 20 – Accessory Screening

Formatted: Highlight

## CITY OF TUCSON PUBLIC UTILITY ADMINISTRATIVE MANUAL

### 11.7 POLE COLOR COORDINATION

Various colors have been selected by affected neighborhoods. New colors may be added based upon input received during the Public Interaction Meeting. Here are the colors to date:

**No Color-** Galvanized (standard)

**Tucson Auto Mall:**

- Vendor: Benjamin Moore & Co.
- Color: Bronzestone #163-60 also known as "Ironclad Retardo"

**Central Business District (Gucci Pole):**

- Vendor: Sherwin Williams (Envirolastic 940 DTM)
- Color: "Tempe Brown"

**Concrete Pole:**

- Vendor: Powder Technology Inc.
- Color: Concrete Gray PB, Lab Number XTA1913, known by COT as "Concrete Aggregate" *(painted concrete color with specks in the paint simulating an exposed aggregate look of a concrete pole)*

**Downtown Streetcar:**

- Vendor: Valmont
- Color: RAL 7013-Valmont, #350318 also known as Product: B13294TM15K

**Historic Flat Black & Silver:**

- Vendor: Dunn-Edwards
- Color: DEA 187, EVSH10 also known as "Black"

*(The flat black is applied from the pole base to a horizontal or transverse line across the diameter of the pole 6-ft above the base)*

- Vendor: Dunn-Edwards
- Color: DE 6367 also known as "Covered in Platinum"

*(The silver is applied from a horizontal or transverse line across the diameter of the pole, 6ft above the base, and up to the top of the pole)*

- Galvanized Poles: Silver paint is not required above the black portion.

**Mountain Avenue:**

- Vendor: Valmont
- Color: Columbia Cascade Caspax -7, Evergreen, Product Number DS-50-59A220 – 6S Finish known by COT as "Forest Green"

**Scott Avenue:**

- Vendor: TIGER Drylac
- Color: RAL7013



## CITY OF TUCSON PUBLIC UTILITY ADMINISTRATIVE MANUAL

### Wood Pole:

- Vendor: Dunn-Edwards
- Color: DE6112 also known as “Cedar Chest”

### Meter Cabinet:

- Vendor: Dunn-Edwards
- Color: DE6137 also known as “Tan Plan”

### Pink/Salmon Pole:

- Vendor: Powder Technology Inc.
- Color: Desert Storm C.B., Product Number PT-US52-NS06 known by COT as “Desert Sandstone”

### 11.8 TREES

SWF poles shall not be placed in water harvesting areas without proper precautions and care to protect and maintain trees and shrubs that could be impacted by the construction activity. SWF poles shall be separated from existing trees and their canopy along property frontages. A separation of 25-feet is desirable.

**Commented [JS31]:** This color MAY no longer be manufactured. I should know Wed 5/12

**Commented [JS32R31]:** If obsolete, I will provide replacement color.

**Commented [JS33]:** New color: Home Depot - BEHR, Granite Grip – “Ubatuba” color combination.

Painting process:

1. Paint pole with primer that adheres to the metal pole
2. Paint pole with Home Depot - BEHR, Granite Grip – “Ubatuba” color combination
3. Paint with a shiny clear coat



Figure 21 – SWF Poles in Amenity Zone

## **CITY OF TUCSON PUBLIC UTILITY ADMINISTRATIVE MANUAL**

### **11.9 SETBACK LOCATIONS**

SWF poles proposed along arterials streets or collectors must be set back from the curb and be located behind an existing sidewalk or future 6-foot to 8-foot sidewalk area. The pole may not be located closer than the nearest streetlight pole at street corners having existing traffic signals. If less than the desired pedestrian path separation is available, the provider may install a curb access ramp with a reduced dimension having no less than 5-foot in width.

SWF poles proposed in residential neighborhoods may place the pole behind the curb at existing street sign locations provided there are no additional support communications equipment above ground such as a metered pedestal cabinet. Placement of the SWF pole must consider pedestrian access to meet current or future ADA compliance setbacks.

A SWF pole may replace an existing signpost at a local street intersection in a residential neighborhood provided the following criteria are met:

1. It is physically separated to provide the pedestrian access is provided for and no other above ground equipment is included,
2. The curb access ramp at the street corner is modified as part of this construction to meet ADA regulations, and confirmation that any other existing utility apparatus-such as the use of a fire hydrant will not be affected.
3. The pole may not block existing fire hydrants.

If other types of utility poles (wood or steel) exist in the vicinity of the proposed SWF pole location, the cellular provider should collocate to this pole unless there is sufficient separation (150-ft min) between the existing utility pole and the proposed SWF pole as described herein.

### **11.10 Property Frontages and Common Property Lines**

SWF poles may not be placed anywhere along a residential frontage except for at property corners unless approved by a Utility Waiver Request.

In some cases where driveways are at locations that are in nonconformance with current driveway approve locations per the City Code, Chapter 25, poles may be placed to meet the intent of separation between driveways and to be close to the property line. A distance, no less than 5-foot from existing driveways should be maintained without additional protection such as post barricades.



**CITY OF TUCSON PUBLIC UTILITY ADMINISTRATIVE MANUAL**



**Figure 22 – Separations from Driveways and Trees**



**Figure 23 – Pole Location at Common Property Line**

## **CITY OF TUCSON PUBLIC UTILITY ADMINISTRATIVE MANUAL**

### **11.11 SWF DESIGN WAIVER REQUEST**

Should the installation vary from the location approvals provided by these guidelines a written request for waiver of the specific deviation shall be forwarded for review and approved by the Utility Coordinator.

A waiver must be part of the review application and proof that all other design options have been explored to meet the intent of these guidelines. The waiver shall contain:

- **DESCRIPTION:** the description of the infrastructure proposed and the public review interaction.
- **LOCATION:** The location of proposed facility and list of accessory equipment shall be provided.
- **REASON:** Provide the reason why a waiver is requested.
- **IMPACTS:** List the impacts to other utilities and to citizens or businesses.
- **DESIGN OPTIONS CONSIDERED:** Describe what other considerations were made before moving to the waiver request and why they do not work here.
- **CONCESSION:** Describe what will be done as a concession if this waiver is approved. This may include screening, protection, pavement replacement, additional landscape or other improvements that are beyond the scope of this improvement.

The City of Tucson will review and provide a response within five business days.



## CITY OF TUCSON PUBLIC UTILITY ADMINISTRATIVE MANUAL

### 12. DESIGN REVIEW STEPS FOR ALL UTILITY ROW PERMITS

These are the steps that will generally be followed. The status will be provided online. Plans and review requests can be made at [DOT-Engineering-Review-Section@tucsonaz.gov](mailto:DOT-Engineering-Review-Section@tucsonaz.gov)

The number of people needed to complete the review is based upon the complexity, the impacts, and whether accurate information provided by the Utility Company's consultant is contained in the ROW application.

**Commented [SC34]:** This image is really small...any way to make it larger on the page?

- DTM Staff receive plans and ROW Permit from Applicant.
- DTM Staff verify License Agreement/ Franchise Agreement Status (if applicable).
- Staff review for completeness (Y/N). If complete, assigned for review. If not complete, send notice to applicant.
- Applicant provides missing information. DTM notifies Applicant of acceptance if complete.
- Administration fees paid by Applicant.
- Applicant sends notification out to public, copies Utility Coordinator, Ward Offices, and neighborhood. Public comment period: 15-business days applies to NEW infrastructure only. (Emergency or maintenance requests do not go through this design notification process.)
- DTM Utility Coordinator distributes to review staff.
- Staff reviews for compliance to the design requirements herein and provides comments to the Applicant. Comments are made available online.
- Utility Company is notified of status. Approved or disapproved.
- If disapproved, the Applicant shall be ~~notified~~notified, and modifications shall be made to the appropriate documents. ~~Another review~~Another review and resubmittal may be necessary if modifications are not made completely and satisfactorily. Resubmittal made by Applicant.
- Official approval given by City of Tucson. Permit fees paid by Applicant.
- Permit issued. NTP meeting scheduled.
- Construction expectations ~~discussed at a~~discussed at a ~~Notice To Proceed (NTP)~~Notice To Proceed (NTP) meeting ~~held~~held with Inspection Coordinator. Dates, description, and contact info on resident notification confirmed.
- Resident Notifications made by Utility Company when work is scheduled and ready to start (5-days in advance).
- On Site inspection meeting held before work begins. Proof of notifications provided. (Work cannot start until this meeting held.)
- Work Begins
- Milestone inspections scheduled and made live or virtually.
- Project completed, inspected, site restored. Live walk through scheduled.



## **CITY OF TUCSON PUBLIC UTILITY ADMINISTRATIVE MANUAL**

- Record drawing and materials testing support information provided to inspector at walk through.
- ROW Permit closed out.

**RESERVED FOR FLOWCHART OF THE PROCESS**

DRAFT





## CITY OF TUCSON PUBLIC UTILITY ADMINISTRATIVE MANUAL

### 13. CONSTRUCTION PROCEDURES

Upon receiving confirmation that a permit has been approved, the Applicant or Applicant's contractor shall take steps to do the following:

#### 13.1 CONSTRUCTION NOTIFICATIONS REQUIRED

Before a preconstruction meeting is scheduled, the Utility Company shall ~~notify residents~~ ~~distribute door hangars~~ five (5) days in advance of the start of construction. ~~Notification shall be made to~~ residences within 300-feet of the proposed site explaining what will occur. ~~This requirement does not apply to Maintenance, Emergency Restoration, commercial business~~ ~~commercial business~~ and residential service connections, or to work completed by utilities with a voter-approved Franchise Agreement..

Formatted: Highlight

Formatted: Highlight

~~Resident Notifications~~ ~~Door hangars~~ shall include:

Formatted: Highlight

- A description of the work to be done;
- The start and expected end dates;
- The expected work hours;
- A description of coordination measures to be taken during construction for parking, pedestrian access, mail delivery, garbage pickup, and miscellaneous needs;
- The Utility Company contact information during regular business hours.

A sample containing the information to include is provided at <https://www.tucsonaz.gov/tdot/permits-and-codes-section>.

Provide a listing of the properties that resident notifications were issued to and a copy of the actual notification issued. The notification must contain the appropriate information described in the steps listed to be acceptable. Provide this information to the Inspector at the Preconstruction Meeting. If the notification is incomplete, it will need to be reissued to the residents ~~omitted~~. ~~No work may commence until the Inspector confirms the notifications have been issued.~~ The City shall provide the addresses of the impacted residents and neighborhood association contact information to the Utility Company requiring notification. ~~The Utility Company shall not be held responsible for failing to notify those not included on this list.~~

Formatted: Highlight

For New Projects, the Utility Company will establish a point of ~~contact for~~ ~~contact for~~ the given New Project to serve the citizens of the City of Tucson.

NOTE: Weekly meetings will be held to assess effectiveness of the cooperation with the residents.

#### 13.2 PRECONSTRUCTION MEETING REQUIRED

A preconstruction meeting must be held before construction may begin to outline the expectations to be followed during construction. The availability of the inspector for a



## **CITY OF TUCSON PUBLIC UTILITY ADMINISTRATIVE MANUAL**

preconstruction meeting and various progress inspections shall be accomplished using phone, email, and video conferences.

At a minimum, the topics to be covered at the preconstruction meeting between the Utility Company and Inspector shall include the following topics:

- **Resident/Business Notification verification**
- **Work hours**
- **Material Submittal documentation**
- **Communication and expectations**
- **Site Safety expectations**
- **Mobility considerations**
- **Required inspections (for SWF: add foundation, pole delivery, installation, connections)**
- **Design changes**
- **Final inspection (for SWF: add testing)**
- **Close out (for SWF: add power approval)**

Every day the permit is open necessitates maintenance of the site and inspection of the site. The Utility Company is encouraged to complete work as soon as possible. **Work on weekends is not permitted without advance notification and inspection overtime fees.**

### **13.3 COPY OF PLANS AND PERMIT**

Permits will be posted online by the City of Tucson. The Utility Company will be required to have a hard copy of the permit and plans with him when on site. Construction may not begin until the notifications and a preconstruction meeting have been scheduled.

### **13.4 CONSTRUCTION ZONE PROTECTION**

A hard copy of the mobility control plan shall be with the Utility Company when on site. Plans must address all mobility impacts and provisions to allow users to pass through the site and not redirect them across the street where practicable.

### **13.5 STEEL PLATES**



## CITY OF TUCSON PUBLIC UTILITY ADMINISTRATIVE MANUAL

Open excavations shall be secured with steel plates and shall be secured in place per the latest PAG Detail. All steel plates must be secured with either a cold mix wedge per **PAG Standard Detail 217** or recessed into the existing pavement as follows:

- Steel plates shall be recessed into the pavement on streets where posted traffic speeds exceed 25-mph and all downtown streets or MITZ.
- Construction locations where steel plates are used, and where work is to take longer than 5-days shall be recessed into the pavement regardless of if it is in a residential location.



The number of inspections will vary based upon the activity and milestones. Site safety will be checked regularly, and good housekeeping measures always enforced. Inspections might be made on site, virtually, and in case of emergency sufficient notification and documentation required by the ROW Permit process made in a reasonable and prudent time.

### 14. INSPECTION EXPECTATIONS

Except for Emergency Restoration, Maintenance, or commercial business and residential service connections, no work may be done unless a permit is active, resident notification made, and a preconstruction conference has been held.

Formatted: Highlight

Formatted: Font: Not Bold, Highlight

Formatted: Highlight

Preconstruction meetings may be on site or virtual depending on the scheduling and availability of the Inspector.

#### 14.1 PROGRESS INSPECTIONS

The DTM Inspector shall make regular scheduled or nonscheduled progress inspections. The construction site must be safe, clean, and all work in compliance with the PAG Standard Specifications and Details. Failure to meet these requirements are grounds to stop work.

#### 14.2 FIELD DESIGN CHANGES

Field design changes may be necessary when incorrect plan information is discovered that conflicts with actual filed information. Major design changes must be submitted to the department for review and approval. The decision to make changes in the field shall be guided by the following:

- **Minor change**

A change in alignment of no more than 5-ft horizontally and 2-ft vertically is considered minor. The infrastructure must remain in the same specified, approved, utility ~~corridor~~, ~~corridor~~. Utility Companies are required to submit updated plans to the Inspector but are not required to obtain approval.

Formatted: Highlight

Formatted: Highlight



## CITY OF TUCSON PUBLIC UTILITY ADMINISTRATIVE MANUAL

- **Major change**

An alignment, or location change exceeding the description for a minor change. A major change shall require a plan revision that will need to be submitted for review and approval for location and/or depth.

### 14.2.1 Field Change Approval

All major changes to the design as described above require an updated plan to the department and the content must be conformed with the require approval by the Inspector.

Formatted: Highlight

Formatted: Highlight

### 14.3 GOOD HOUSEKEEPING MEASURES

At a minimum, the following checklist shall be considered and followed during the planning, design, and construction of new, modified, or maintained utility infrastructure:

- Off-site construction support activities.
- Spill prevention and response.
- Vehicle and equipment entrances.
- Chemical and materials storage.
- Solid waste management.
- Dust control.
- Soil stabilization.
- Erosion control.
- Any non-stormwater discharges.



The Utility Company should refer to the ADOT Erosion and Pollution Control Manual to determine the best management practices (BMP) for each item listed above.

### 14.4 MATERIALS TESTING AND CERTIFICATION

The Utility Company shall provide the inspector with records of material delivery tickets for materials used on site to backfill and patch the street. Materials used must meet current City of Tucson mix designs on file with the DTM Testing laboratory. Material density test results shall also be provided at the frequency required for the respective type and quantity of the material as discussed at the preconstruction conference. The records shall reflect the date, time, and company providing the material or tests.



## **CITY OF TUCSON PUBLIC UTILITY ADMINISTRATIVE MANUAL**

These delivery tickets and testing results may be a pdf or jpeg format. Copies shall be emailed, or text messaged with attachments for record proof of the quality of work performed at the respective construction site.

### **14.5 FINAL INSPECTION AND CLOSE OUT**

A final inspection will need to be made so that the permit can be closed out. If the site is unacceptable, the permit will not be closed out. Renewal of the permit will need to be made if the Utility Company is out of time and work is not completed.

DRAFT



## CITY OF TUCSON PUBLIC UTILITY ADMINISTRATIVE MANUAL

### 14.5.1 Record Drawings

The Utility Company is required to keep the construction documents with it and make all necessary changes to the plans. A final document shall be provided to the City Inspector at the completion of the work along with bore logs, elevations, and dimension changes that were confirmed during construction. The document may be a pdf hard copy or an electronic pdf attachment sent through an email.

Formatted: Highlight

Formatted: Highlight

Formatted: Highlight

Formatted: Highlight

Copies of dDelivery tickets and testing results shall be provided and made part of the permit record.

### 14.6 ROW PERMIT CLOSE OUT

A permit shall not be considered closed out until the site is restored to its original condition or better; the site is cleaned up; barricades are removed; and record drawings are provided to the City in hard copy or electronic format (PDF).

The final information shall be made a part of the permit record.

See Exhibit F for a ROW Permit Closeout Checklist

### 14.7 PERMIT DURATION

The permit duration shall be as applied for unless renewals have occurred. Work that is done under an expired permit may warrant a citation for work without a permit.

ALL Work must be completed within this time. Additional permits may require a delay in completing the work per the Utility Company's schedule and make availability of materials difficult. In some cases, other work and activities will compete for space and restriction consequences. The costs to all who are responsible for the site safety and compliance add up each day that work is not completed. Additional fees may be assessed if work is done after the permit expiration and if not renewed.

Commented [ES35]: Is there a timeline expectation for the city to review and approve permits?

#### 14.7.1 Number of Permits Allowed to Remain Open at One Time

It is the intent to make any utility installation less impactful to the City of Tucson residents. Quick prosecution of the work is expected and will help develop better public relations with the City of Tucson residents. Work is encouraged to be completed as soon as possible and within the approved permit duration. Regulation of permit approval and issuance will be employed to ensure that this intent is met.

**Utility work is either a New Project, Maintenance, or Emergency Restoration. The direction in this section applies to New Projects.**



## CITY OF TUCSON PUBLIC UTILITY ADMINISTRATIVE MANUAL

- No more than 100 permits will allowed to be renewed, where minor work is required to close out the final requirements will be allowed to be renewed. This may affect the ability of the applicant or their agent to receive future permits. Renewals must be made in anticipation of the permit expiring and remaining work starting within 30-days of the approved renewal date.
- No more than 100 construction sites per Utility Company will be allowed to remain open and under construction. Sites must be completed, inspected, and finalized before consideration of future requests will be given. As sites are closed out, new sites will be advanced. Demonstration of cooperation and consistency may allow sites to be under constructioned at one time.

The City reserves the right to reduce the number of permits based upon staff availability and Utility Company performance to address complaints in a timely manner. This shall include removing aerial fiberoptic lines from poles scheduled to be removed. -

### 14.8 FAILURE TO COMPLETE ON TIME

The ROW permit will not be extended beyond the approved duration. Should follow up work be required, a new permit will need to be obtained. This shall be followed for temporary patching that may be installed and scheduling of the permanent patch is delayed due to unavailability of materials only. Proof of unavailability shall be required.

### 14.9 ABATEMENT

Abatement for violations of these standards shall consist of a reduction in permits issued. The number of permits allowed to remain open may shall be determined by the City Engineer, or designated representative. Correction shall be made by the Utility Company within 10-days of written notice. The number of permits reduced is suggested to be shall be the number of days that violations remain unaddressed are not addressed.

### 14.10 MODIFICATIONS AND APPEALS

#### 14.10.1 Modifications

Emergency situations and other conditions not specifically addressed by this standard shall be judged on a case-by-case basis by the City Engineer, or designated representative, without setting precedent.

Review of and modifications to this manual shall be made on July 1st each year.

Formatted: Highlight

Formatted: Highlight

Formatted: Highlight

Formatted: Highlight

Formatted: Highlight

Formatted: Highlight

Formatted: Highlight

Formatted: Highlight

**Commented [ES36]:** TEP requests requirements for renewal of permits be added to the Manual. Pima County allows for two renewals, TEP proposes the same process here

Formatted: Highlight

Formatted: Highlight



## CITY OF TUCSON PUBLIC UTILITY ADMINISTRATIVE MANUAL

### 14.10.2 Appeals

Appeals to rulings made under this standard shall be to the Director of Transportation, whose decision shall be final.

**Commented [ES37]:** TEP requests a more detailed process be outlined (similar to amendments)

# EXHIBITS





**CITY OF TUCSON PUBLIC UTILITY ADMINISTRATIVE MANUAL**

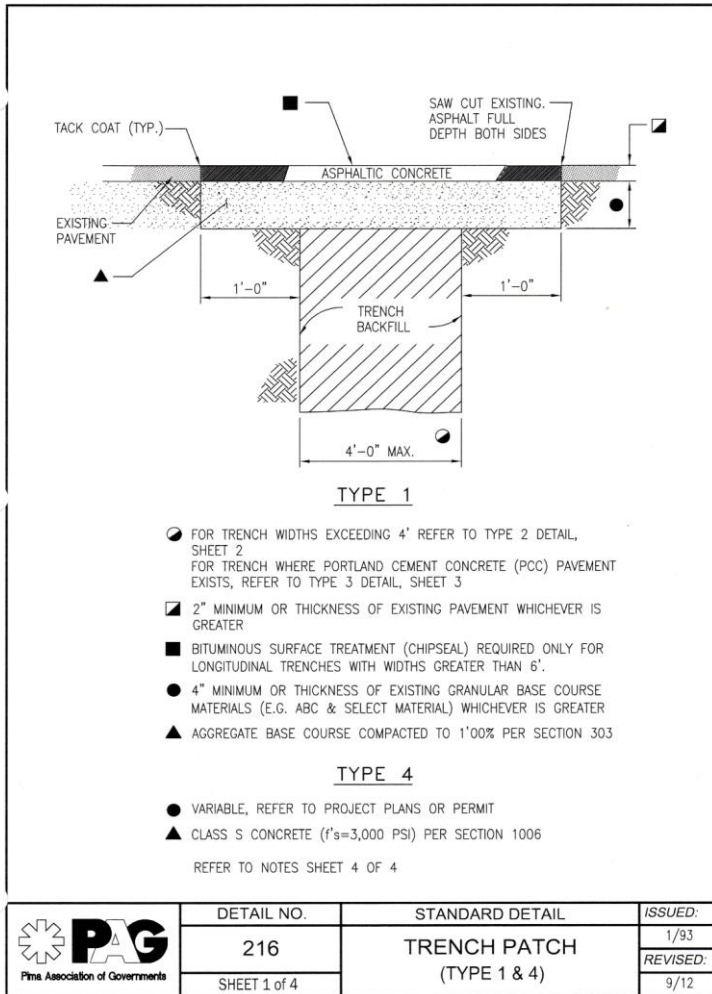

**EXHIBIT A - T-TOP Modified PAG Standard Detail 216 Detail**



**CITY OF TUCSON PUBLIC UTILITY ADMINISTRATIVE MANUAL**

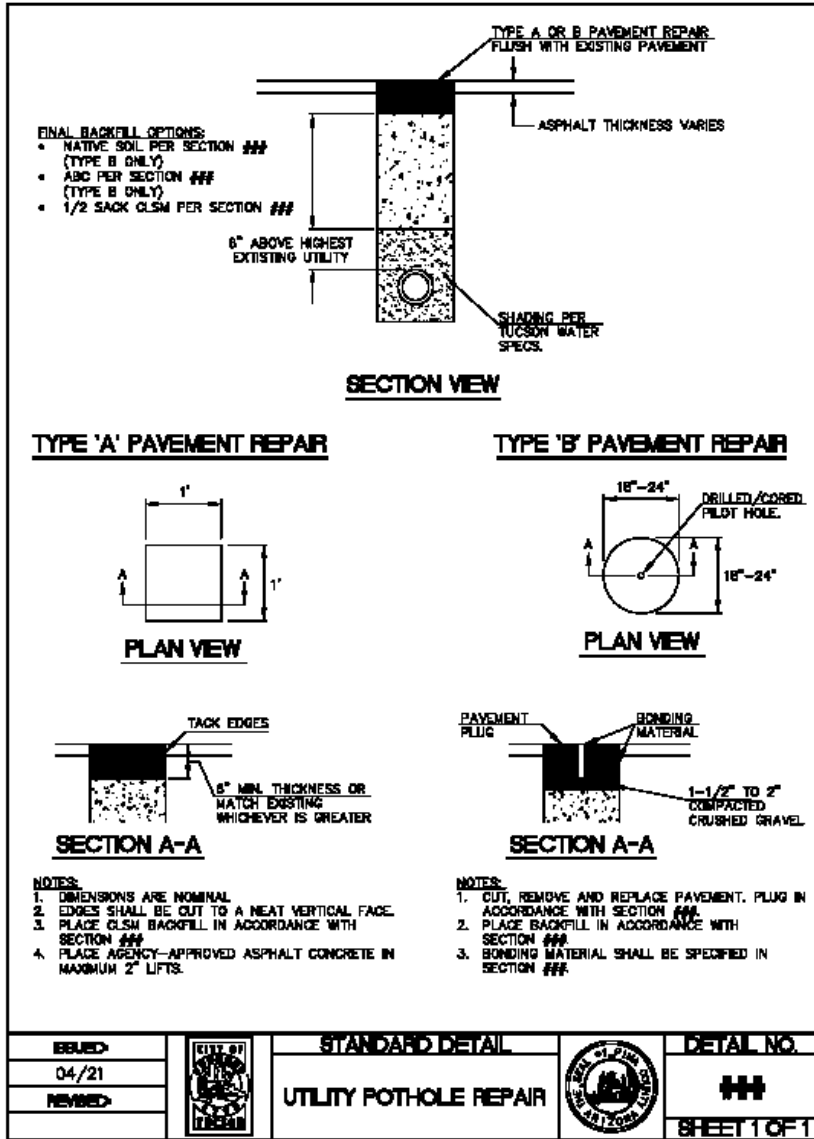

**EXHIBIT B - Pothole Patch**



**CITY OF TUCSON PUBLIC UTILITY ADMINISTRATIVE MANUAL**

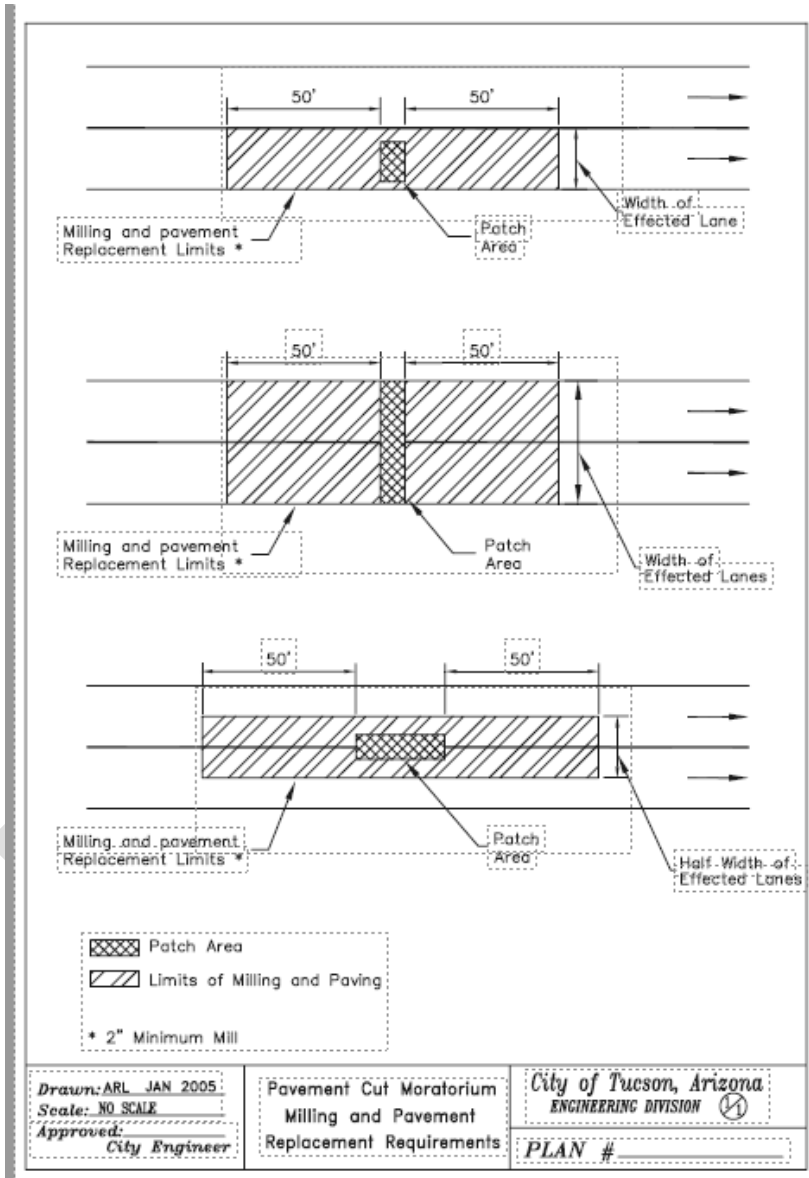

**EXHIBIT C - Moratorium Patch Limits**



## CITY OF TUCSON PUBLIC UTILITY ADMINISTRATIVE MANUAL



### Holiday Restrictions Thanksgiving Day to January 2

#### A NOTICE OF TEMPORARY RESTRICTION TO ALL APPLICANTS, CONTRACTORS, UTILITIES, AND GOVERNMENT ORGANIZATIONS

Due to the ever-increasing traffic volume on many of the City's roads, it is necessary to restrict lane closures on certain roads during the holiday season. These restrictions will be in place from Thanksgiving to one day after New Year's. Engineering may not issue a barricading permit for any project that occurs on any of the following roads. Engineering will grant an exception for documented emergency work or on-going construction work. *Exceptions will be evaluated on a case-by-case basis.*

- |                          |  |
|--------------------------|--|
| > Ajo Way                | Mission Rd to Country Club Rd              |
| > Alvernon Way           | Fort Lowell Rd to 36 <sup>th</sup> St      |
| > Broadway Bl            | I-10 Frontage Rd to Pantano Rd             |
| > Calle Santa Cruz       | Irvington Rd to Valencia Rd                |
| > Campbell Ave           | River Rd to Broadway Bl                    |
| > Congress St            | I-10 Frontage Rd to Toole Ave              |
| > Craycroft Rd           | Grant Rd to Golf Links Rd                  |
| > Downtown Area          | Major Impact Traffic Zone                  |
| > El Mercado Area        | Major Impact Traffic Zone                  |
| > 1 <sup>st</sup> Avenue | Rillito River Bridge to Grant Rd           |
| > 4 <sup>th</sup> Avenue | Major Impact Traffic Zone                  |
| > Golf links Rd          | Swan Rd to Kolb Rd                         |
| > Grant Rd               | I-10 Frontage Rd to Tanque Verde Rd        |
| > Irvington Rd           | Mission Rd to Tucson Bl                    |
| > Kino Parkway           | Broadway Bl to I-10                        |
| > Kolb Rd                | Tanque Verde Rd to Golf Links Rd           |
| > Main Gate              | University Blvd, Euclid Ave to Park Ave    |
| > Oracle Rd              | River Rd to Drachman St                    |
| > Pantano Rd             | Speedway Blvd to 22 <sup>nd</sup> St       |
| > Park Ave               | 29 <sup>th</sup> St to I-10                |
| > Prince Rd              | I-10 Frontage Rd to Campbell Ave           |
| > River Rd               | Oracle Rd to Campbell Ave                  |
| > Roger Rd               | Flowing Wells Rd to N 1 <sup>st</sup> Ave  |
| > 6 <sup>th</sup> Ave    | I-10 to Irvington Rd                       |
| > Speedway Bl            | I-10 Frontage Rd to Kolb Rd                |
| > Stone Ave              | River Rd to Wetmore Rd                     |
| > Swan Rd                | Rillito River Bridge to Golf Links Rd      |
| > Tanque Verde Rd        | Wilmot Rd to Pantano Rd                    |
| > Tucson Bl              | Benson Hwy to Tucson International Airport |
| > 22 <sup>nd</sup> St    | Kino Parkway to Prudence Rd                |
| > Valencia Rd            | Mission Rd to Country Club Rd              |
| > Wetmore Rd             | Flowing Wells Rd to N 1 <sup>st</sup> Ave  |
| > Wilmot Rd              | Tanque Verde Rd to Golf Links Rd           |

Restrictions will be in place for the month of February for areas that involve the Gem Show Event.

- ◆ Gem Show I-10 Frontage Rd

Holiday restricted streets are updated annually. Please review website for existing transportation projects, click [here](#). For additional information, contact the TDOT Permit Center at (520) 791-5100.

EFFECTIVE DEC 2018

### EXHIBIT D - Holiday Restrictions



## CITY OF TUCSON PUBLIC UTILITY ADMINISTRATIVE MANUAL

### **UTILITY WAIVER REQUEST** *(This applies to new utility infrastructure only)*

#### **LOCATION OF THE WORK**

Where is this infrastructure proposed?

#### **DESCRIPTION OF THE WORK OR PROJECT**

Provide a description of the infrastructure to be installed or constructed:

Has there been any opposition from the general public to the project or the location of above ground equipment? Describe the nature of the objection if it exists and where objections have been expressed:

#### **IMPACTS**

Describe if this is above ground, below ground; will impact access; affect street capacity; etc.

#### **REASON**

What is the reason for this waiver request?

#### **DESIGN OPTIONS CONSIDERED**

Describe what has been considered during the design to address public concern and minimize impacts to residents and businesses.

#### **CONCESSION**

*What is your company willing to do differently that will make this acceptable to all affected?*

**Thank you. The City of Tucson will review and provide a response within five business days.**

### **EXHIBIT E - Utility Waiver Form**



**CITY OF TUCSON PUBLIC UTILITY ADMINISTRATIVE MANUAL**

**Exhibit F ROW PERMIT CLOSEROUT CHECKLIST**

Inspection Request Date

Status of Permit

- Expired
- Current
- Renewed

Review for damage

- Curb
- Sidewalk
- groundcover

Landscape

- Irrigation
- Groundcover
- Plants
- trees

Hardscape

- Sidewalk
- Pavers
- Utility markings
- Curb access ramps

Pavement

- Patch
- Microsurface
- Swept

Record Drawings

- Bore logs
- Revisions noted

Quality Control

- Material delivery tickets
- Test results

Barricades

- Removed
- Utility markers

Site Restoration

- Grading
- Repairs

Other

- Formatted: Font: Bold
- Formatted: Font: Bold
- Formatted: Font: 12 pt
- Formatted: List Paragraph, Bulleted + Level: 1 + Aligned at: 0.75" + Indent at: 1"
- Formatted
- Formatted: Font: 12 pt
- Formatted: Font: Bold
- Formatted: Font: 12 pt
- Formatted
- Formatted: Font: Bold
- Formatted: Font: 12 pt
- Formatted
- Formatted: Font: Bold
- Formatted: Font: 12 pt
- Formatted
- Formatted: Font: 12 pt
- Formatted: Font: Bold
- Formatted: Font: Not Bold
- Formatted
- Formatted: Font: Not Bold
- Formatted
- Formatted: Font: Bold
- Formatted: Font: 12 pt
- Formatted
- Formatted: Font: Bold
- Formatted: Font: 12 pt
- Formatted: Font: Bold
- Formatted: Font: 12 pt
- Formatted
- Formatted: Font: Bold
- Formatted: Font: 12 pt
- Formatted: Font: Bold
- Formatted: Indent: Left: 0.2"
- Formatted: Font: 12 pt, Bold
- Formatted: List Paragraph, Indent: Left: 0"



**CITY OF TUCSON PUBLIC UTILITY ADMINISTRATIVE MANUAL**

**Approved** \_\_\_\_\_ **Date:** \_\_\_\_\_

DRAFT

